

alphajoint® 4010

Specification Sheet
Issue 1.0
24/01/2012

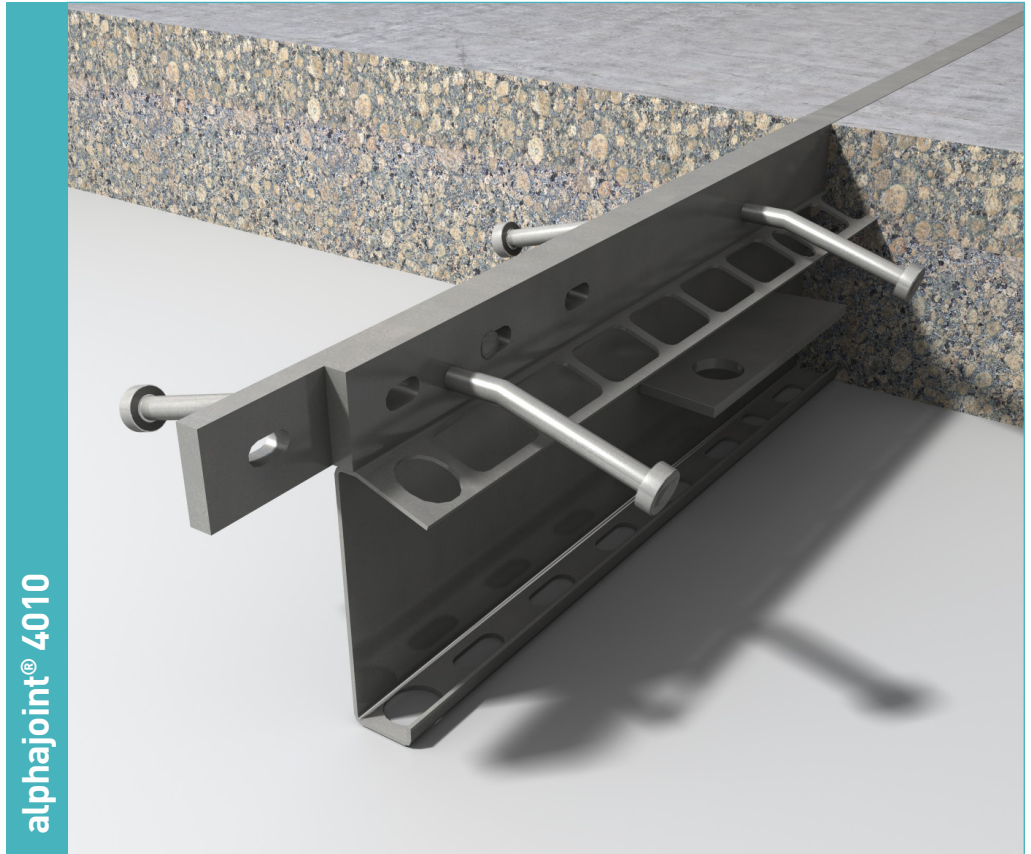

alphajoint® 4010

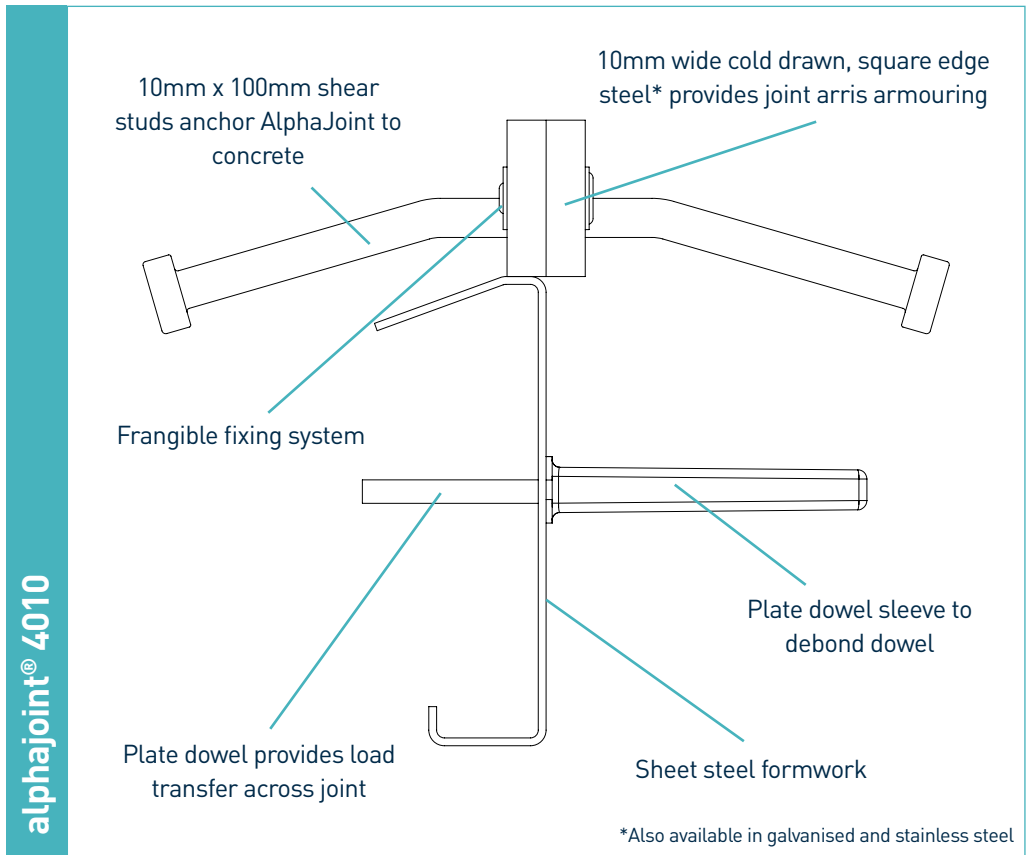

alphajoint® 4010

alphajoint[®] 4010

Specification Sheet Issue 1.0
24/01/2012

manufacturing tolerances

Length ±2.0mm

Height ±1mm

Straightness ±0.5mm/600mm

dimensions of alphajoint[®] 4010

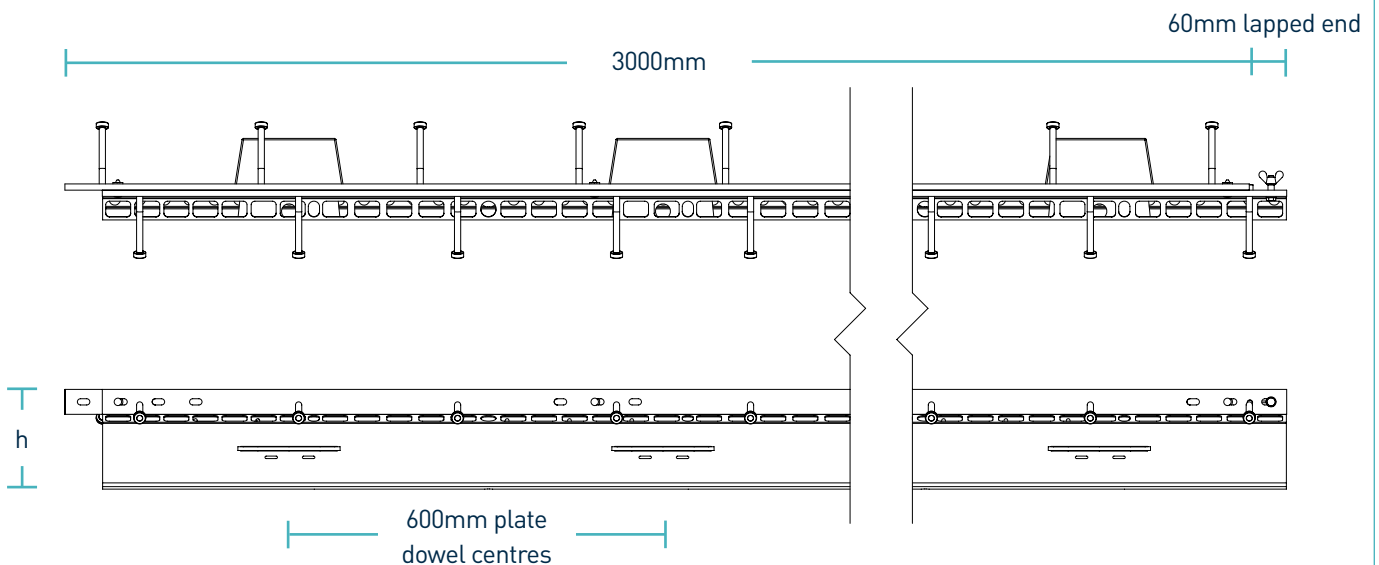

dimensions and weight of alphajoint[®] 4010

Nominal Slab Depth (mm)	Joint Height, h (mm)	Dowel Size (mm)	Dowel Centres (mm)	Length (mm)	Single Joint Weight (kg)	Number Per Bundle	Bundle Weight (kg)
150	120	164 x 120 x 8 Trapeziod	600	3000	34	30	1010
170	140				35	30	1128
190	160				36	28	1085
210	180				37	28	1111

Typical height and length values shown only. Weight values shown are based on AlphaJoint[®] 4010 including TD8 dowels and are approximate.

materials

Component	Material
Joint arris armouring (4010)	BS 070M20
Sheet steel formwork	BS EN 1030:1999 DC01
Shear stud	S275JR or equivalent
Plate dowel	BS EN 10025-2:2004 S275JRG2 min 410 N/mm ²
Plate dowel sleeve	HDPP

alphajoint® 4010

Specification Sheet Issue 1.0
24/01/2012

theoretical calculated ultimate loads at failure of dowel or concrete

(For typical slabs, 40N/mm² concrete and 20mm joint opening)

Slab Depth (mm)	Dowel Type	Unreinforced Slab		Steel Fibre Reinforced Slab (Re3 = 0.8)	
		Bursting (kN/m)	Bending (kN/m)	Bursting (kN/m)	Bending (kN/m)
150	TD6	50.50	80.83	87.17	80.83
	TD8	50.50	143.50	87.17	143.50
	AD10	54.17	328.00	93.50	328.00
200	TD6	82.00	80.83	141.67	80.83
	TD8	82.00	143.50	141.67	143.50
	AD10	63.17	328.00	108.83	328.00
250	TD6	81.00	80.83	136.50	80.83
	TD8	81.00	143.50	136.50	143.50
	AD10	74.33	328.00	125.50	328.00
300	TD6	87.33	80.83	147.50	80.83
	TD8	87.33	143.50	147.50	143.50
	AD10	83.67	328.00	141.17	328.00
350	TD6	94.00	80.83	160.00	80.83
	TD8	94.00	143.50	160.00	143.50
	AD10	91.33	328.00	155.50	328.00

Ultimate load (kN/m)

This table shows the load at failure in bursting (failure of the concrete) and bending (failure of the dowel) for a joint opening of 20mm - larger joint openings can be accommodated. The ultimate load has been calculated in accordance with TR34 3rd Edition. For more detailed analysis please contact Permaban.

compatible dowel systems

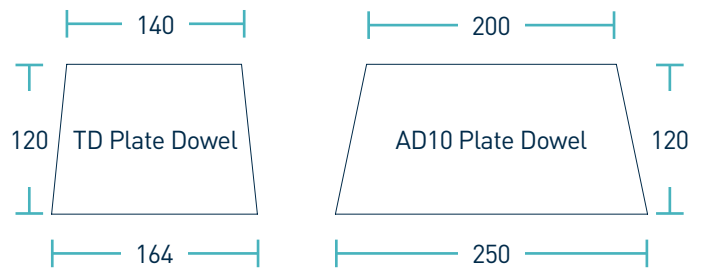

dimensions in mm