

Alpha[®] CSS Accessories

Specification Sheet

Issue 1.1

01/04/2026

Alpha[®] CSS 4-Way

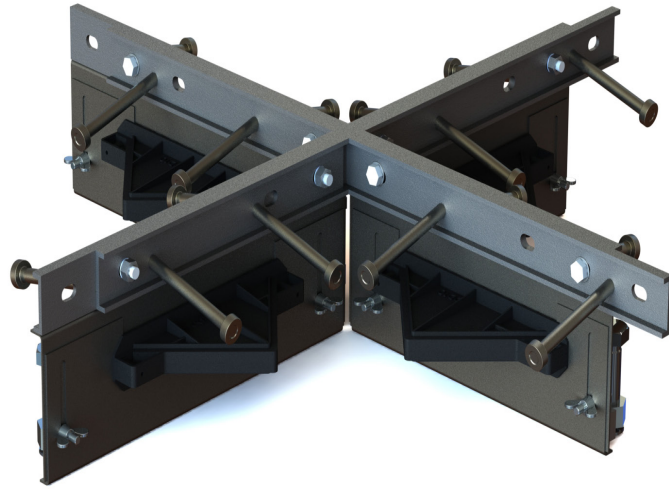

Alpha[®] CSS T-Section

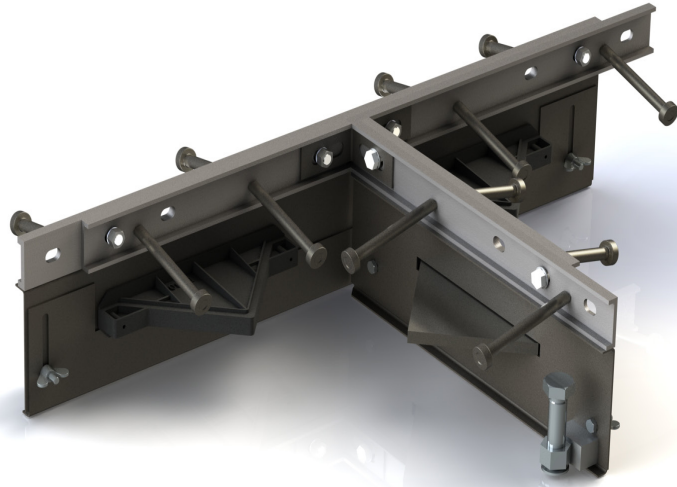

Alpha[®] CSS Dock

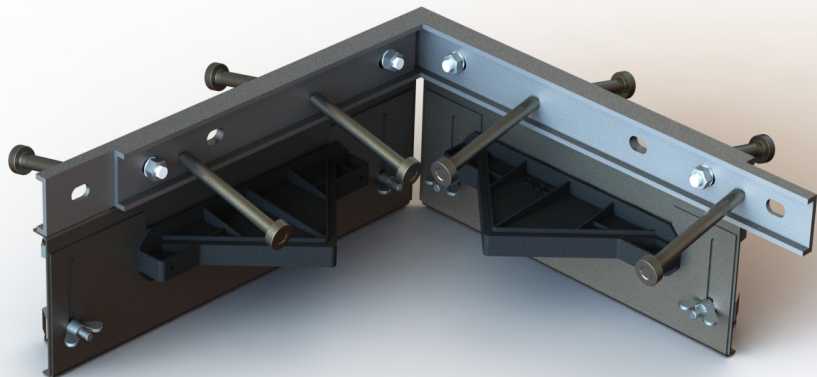

Alpha[®] CSS Accessories

Specification Sheet

Issue 1.1

01/04/2026

Alpha[®] CSS 4-Way

10mm x 100mm shear studs anchor AlphaJoint to concrete

40mm x 10mm C section 304 L stainless steel, provides joint arris armoring

Sheet steel formwork

Frangible fixing systems

Plate dowel and debond sleeve provides load transfer across joints

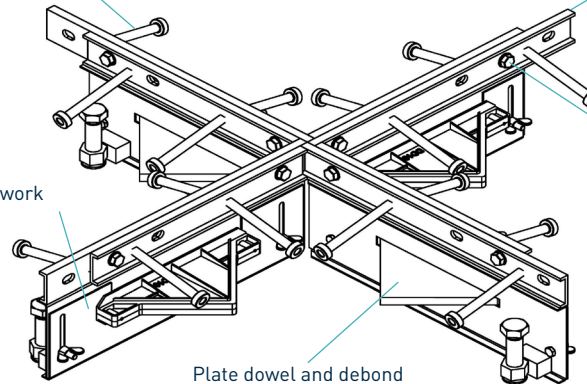

Alpha[®] CSS T-Section

10mm x 100mm shear studs anchor AlphaJoint to concrete

40mm x 10mm C section 304 L stainless steel, provides joint arris armoring

Sheet steel formwork

Frangible fixing systems

Plate dowel and debond sleeve provides load transfer across joints

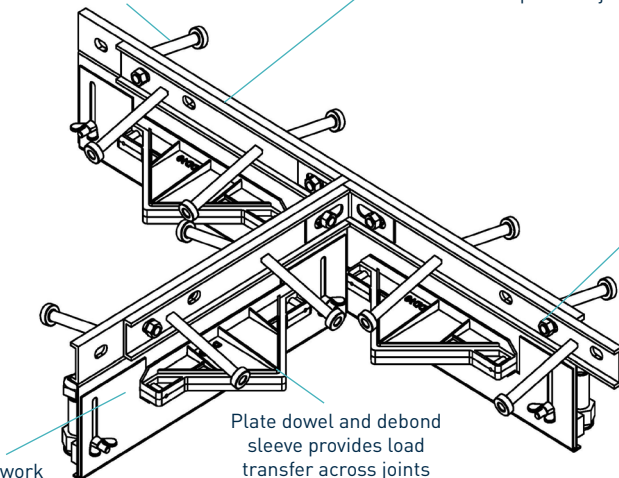

Alpha[®] CSS Dock

10mm x 100mm shear studs anchor AlphaJoint to concrete

40mm x 10mm C section 304 L stainless steel, provides joint arris armoring

Sheet steel formwork

Frangible fixing systems

Plate dowel and debond sleeve provides load transfer across joints

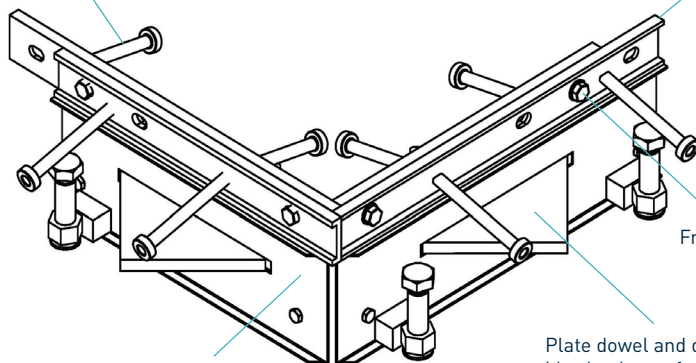

Please note Alpha CSS Docks are supplied as a pair

Alpha[®] CSS Accessories

Specification Sheet Issue 1.1

01/04/2026

manufacturing tolerances

Length	±2.0mm	Height	±1mm	Straightness	±0.5mm/600mm
---------------	--------	---------------	------	---------------------	--------------

dimensions and weights of Alpha[®] CSS Accessories

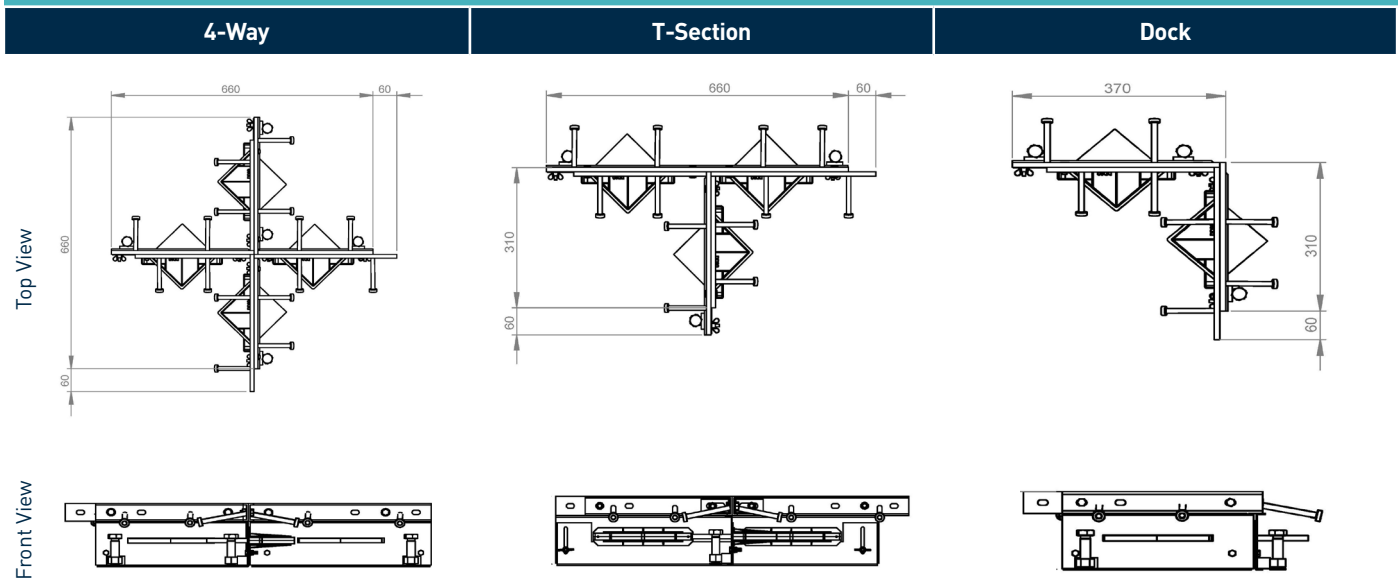

dimensions in mm

dimensions and weights of Alpha[®] CSS Accessories

Accessory	Width (mm)	Length (mm)	Single Weight (kg)	Number Per Bundle	Bundle Weight (kg)
4-Way	720	720	17.7	14	292.8
T-Section	370	720	13.1	28	411.8
Dock	370	370	18.1	14	298.4

Typical height and length values shown only. Weight values shown are based on Alpha[®] CSS 175mm and are approximate.

materials

Component	Material
Joint arris armouring (CSS)	EN 10088-2 1.4301 304L
Sheet steel formwork	EN 10130:2006 DC01
Shear stud	EN ISO 13918:2017 S235J2
Plate dowel	EN 10025-2:2004 S275JR
Plate dowel sleeve	HDPP