

Permaban Beta / Eclipse Installation Guide

Using Alpha Feet Method

Installation Guide Issue V1.0
14/07/22

01 Placing the Eclipse Joint

Place Joints on the floor with sleeves pointing up.

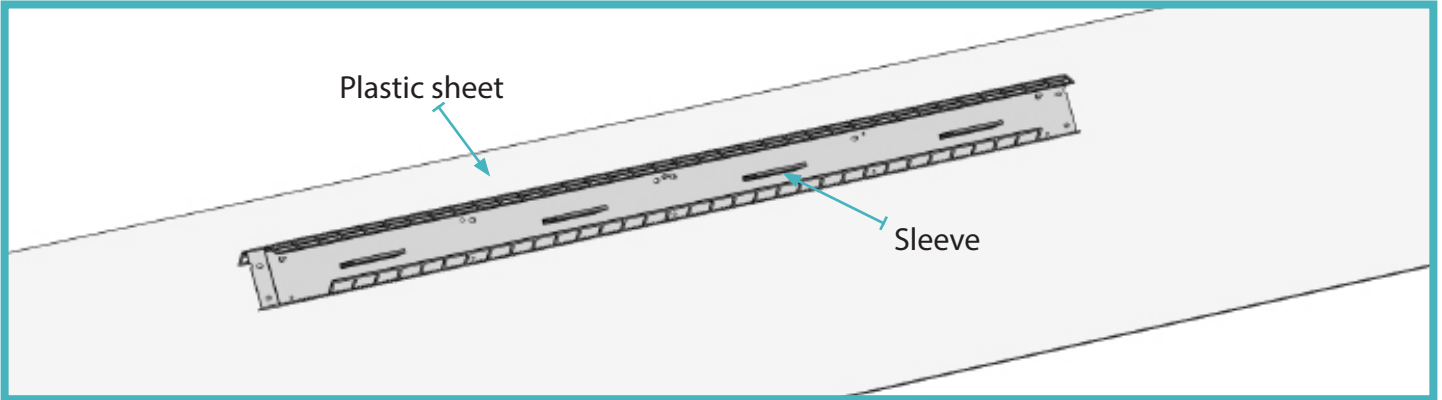

02 Put Joints together

Place Alpha Feet through the hole in the dowel, then push Joints together and assemble with supplied fixtures.

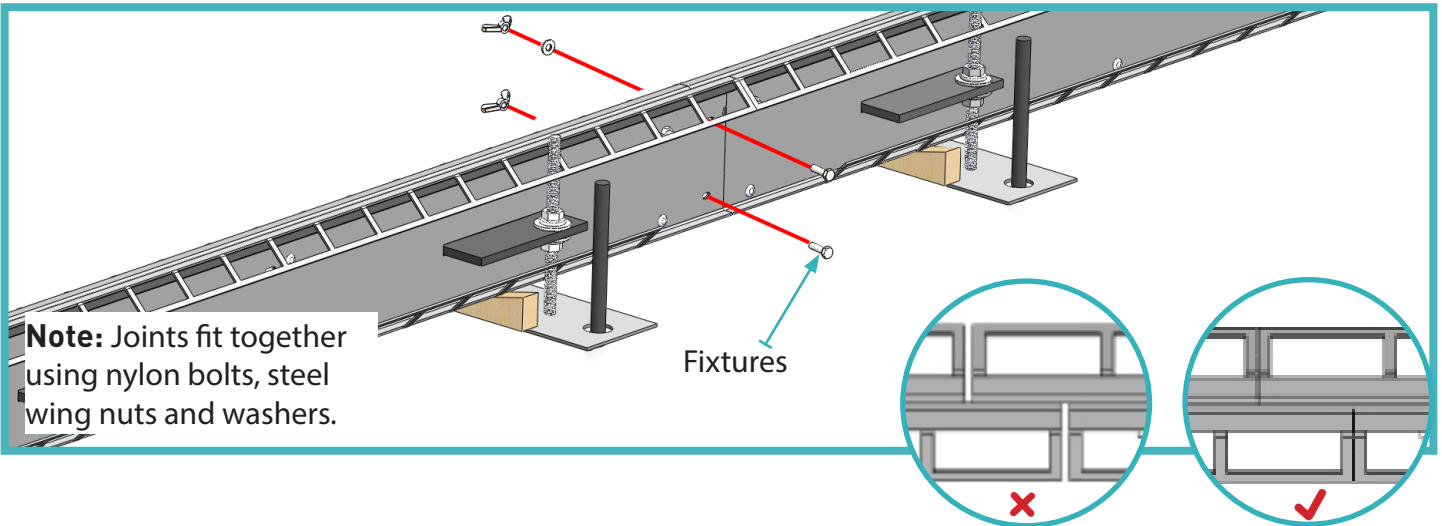
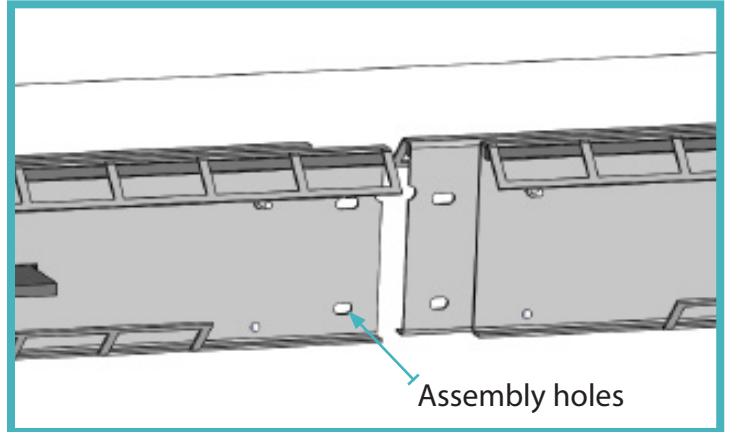
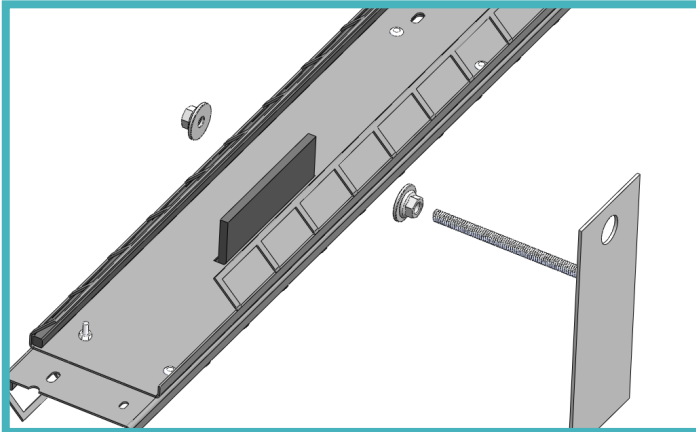

Permaban Beta / Eclipse Installation Guide

Using Alpha Feet Method

Installation Guide Issue V1.0
14/07/22

03 Adjust to Height

Use the bolts to adjust the Joint to the correct height. Wedges are used on both sides and either end to prevent kicking when concrete is poured.

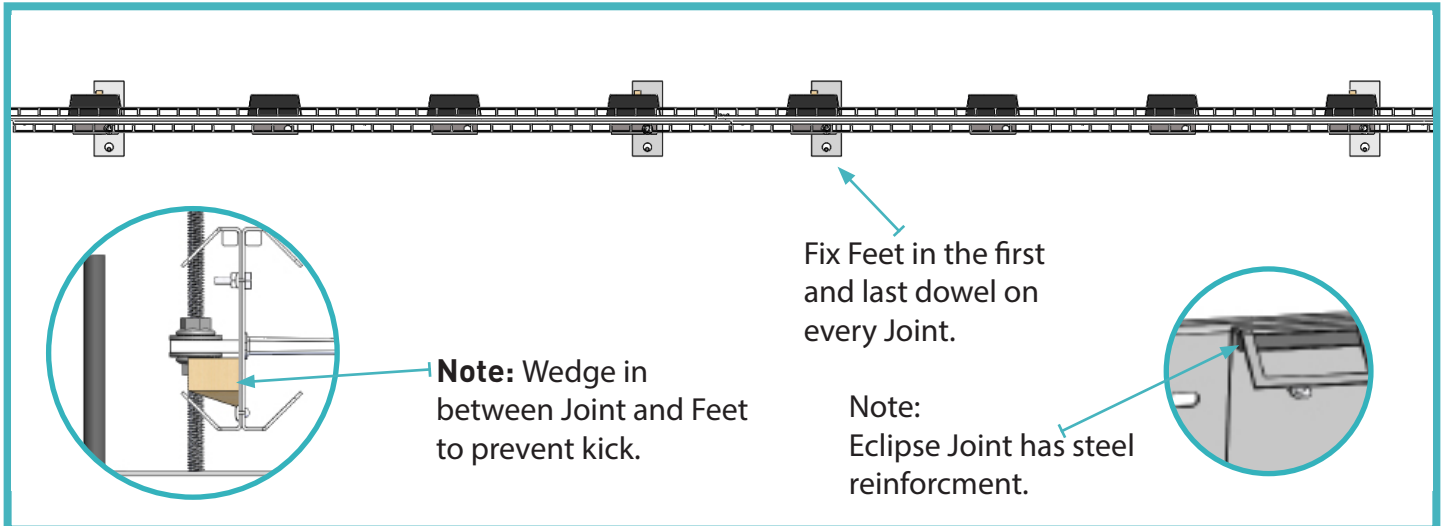

Note; Check the Joint is level at each end of the Joint and once in the center.

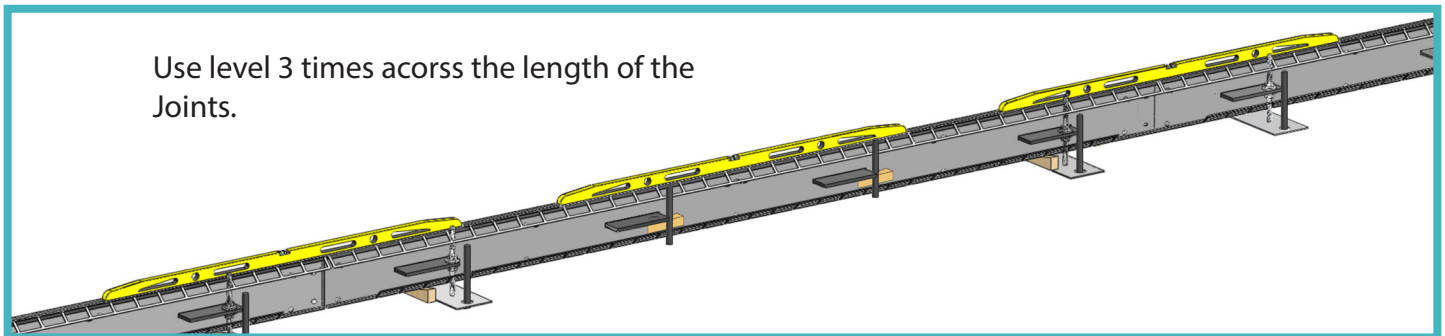

Measure the horizontal level using the top strip.

Note; Joints must be fixed at 90°.

Level

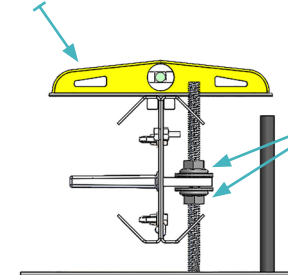

Adjust the nuts on the universal feet to get the correct level.

Permaban Beta / Eclipse Installation Guide

Using Alpha Feet Method

Installation Guide Issue V1.0
14/07/22

04 Vibrate Concrete

Poker vibrate along length of the Joint to compact the concrete.

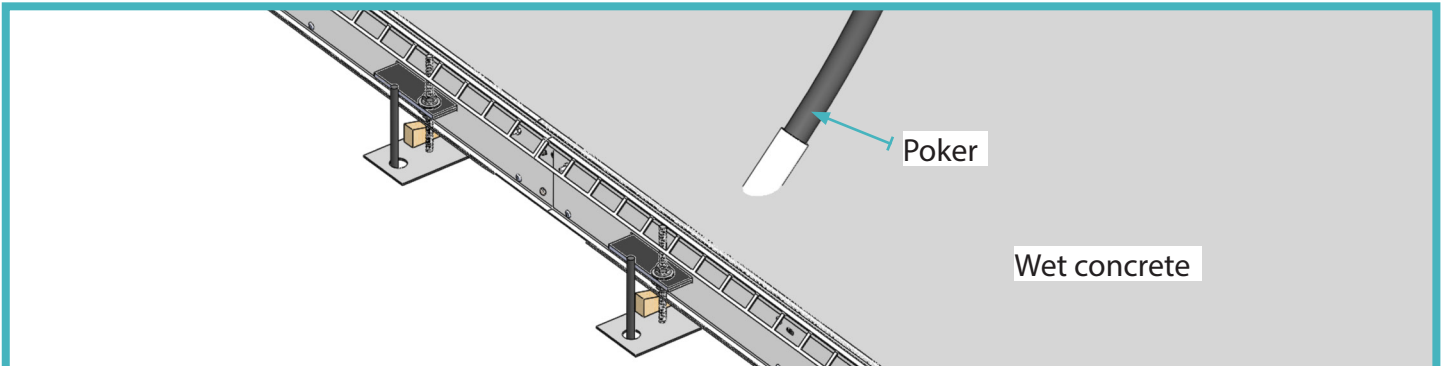

05 Finish

Finish concrete, flush to top of the Joint ensuring the rail is clearly visible. Before next side is cast, cut Joints support pins.