

Permaban Beta / Eclipse Installation Guide

Using AlphaFix Method

Installation Guide Issue V1.0
14/07/22

01 Placing the Eclipse Joint

Place Joints on the floor with Sleeves pointing up.

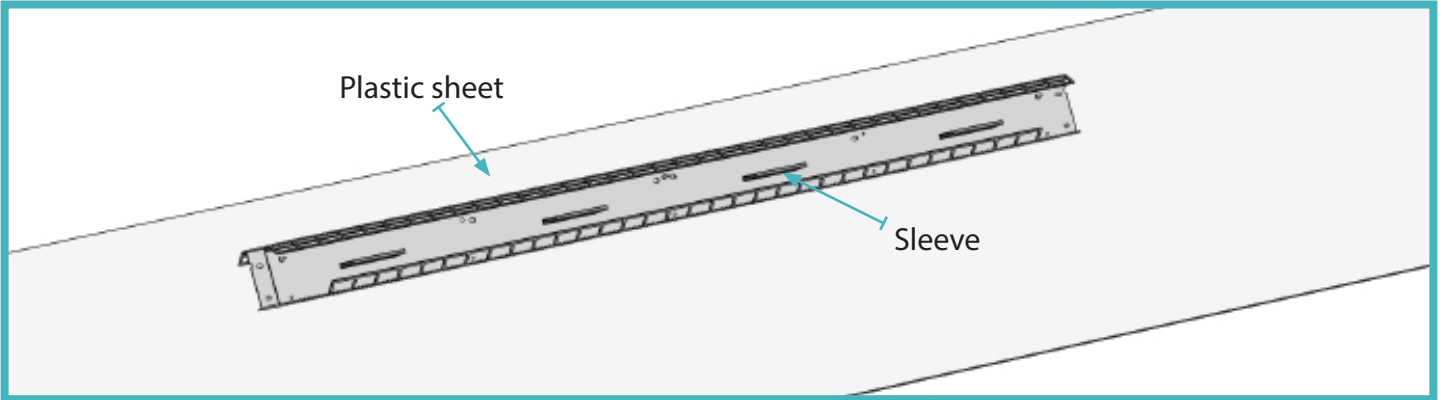

02 Put Joints together

Stand Joints end to end, and fix together using the AlphaFix and install Kit provided, through the joints fixture assembly holes.

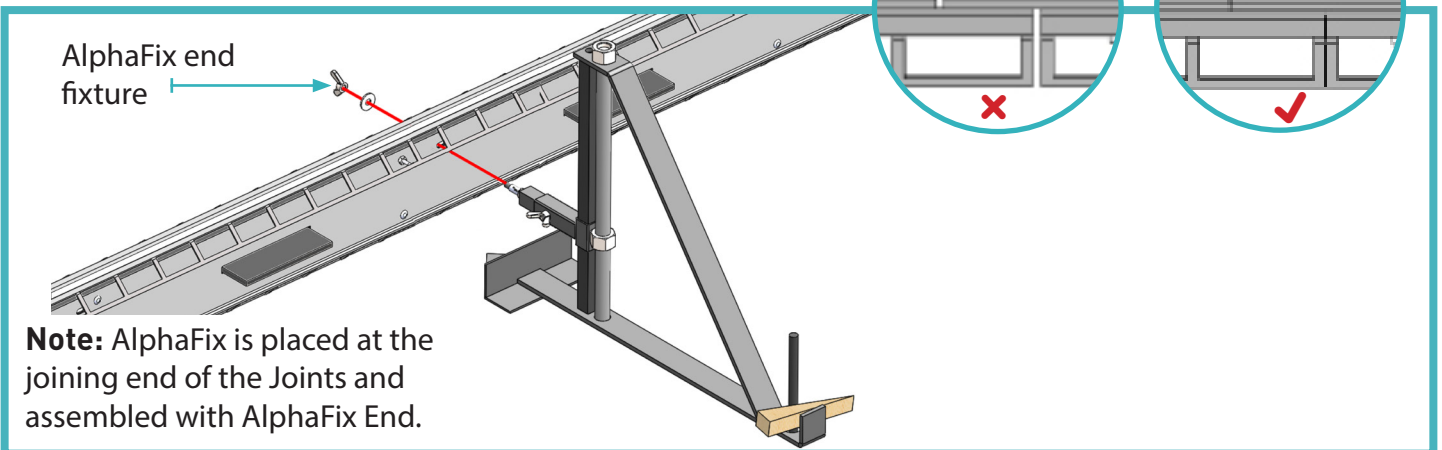
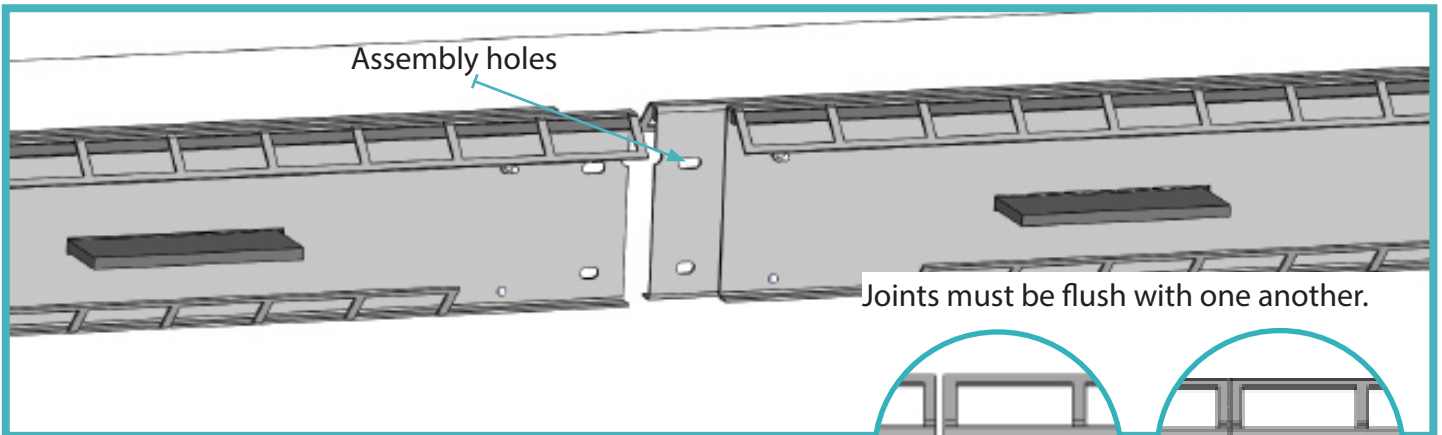

Permaban Beta / Eclipse Installation Guide

Using AlphaFix Method

Installation Guide Issue V1.0
14/07/22

03 Adjust to Height / Level Joints

Use the connected AlphaFix to adjust the height of the Joint. A wedge can then be used in between the Joint and AlphaFix kick stand to prevent kicking of the Joint.

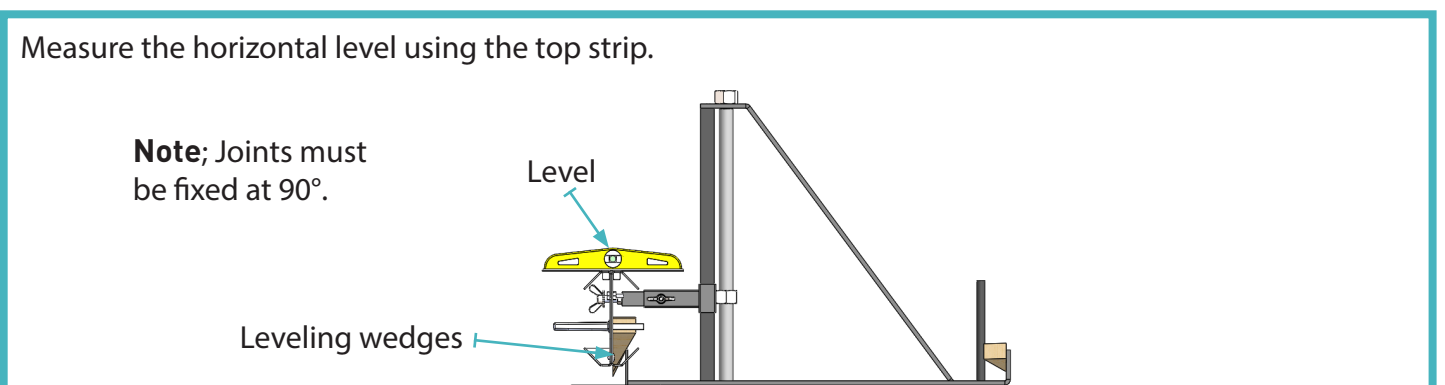
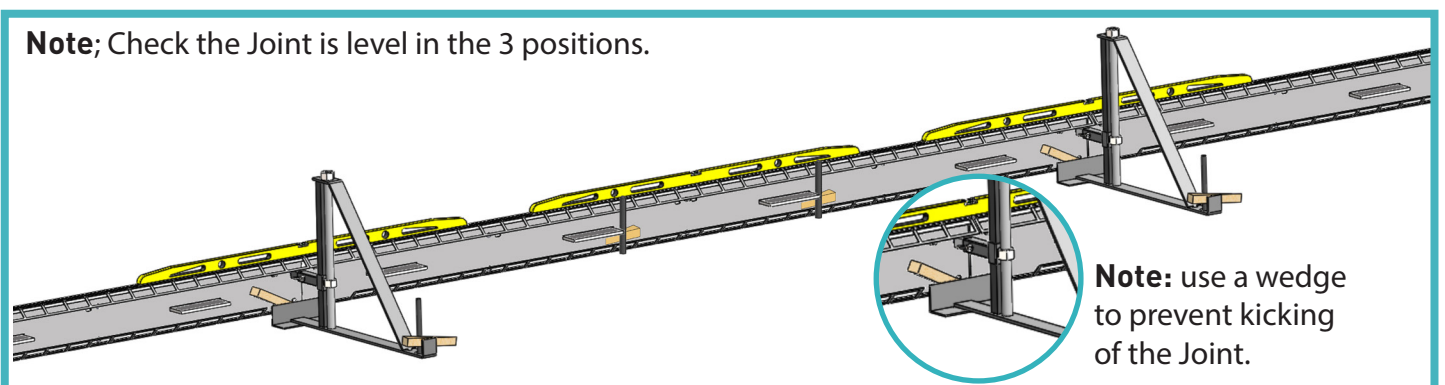
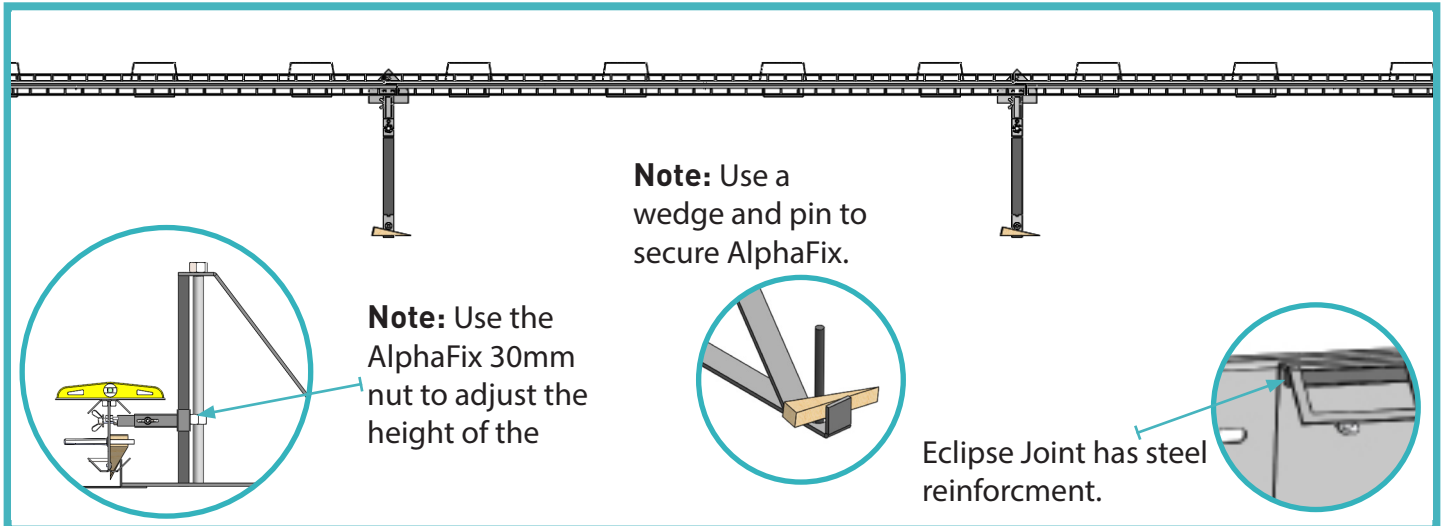

All content found within this installation guide is approximate. RCR Flooring Products Ltd reserves the right to amend this installation guide at any time. For further details, please contact RCR Flooring Products Ltd. RCR Flooring Products Ltd is registered in England & Wales - No. 02815314.

Permaban Beta / Eclipse Installation Guide

Using AlphaFix Method

Installation Guide Issue V1.0
14/07/22

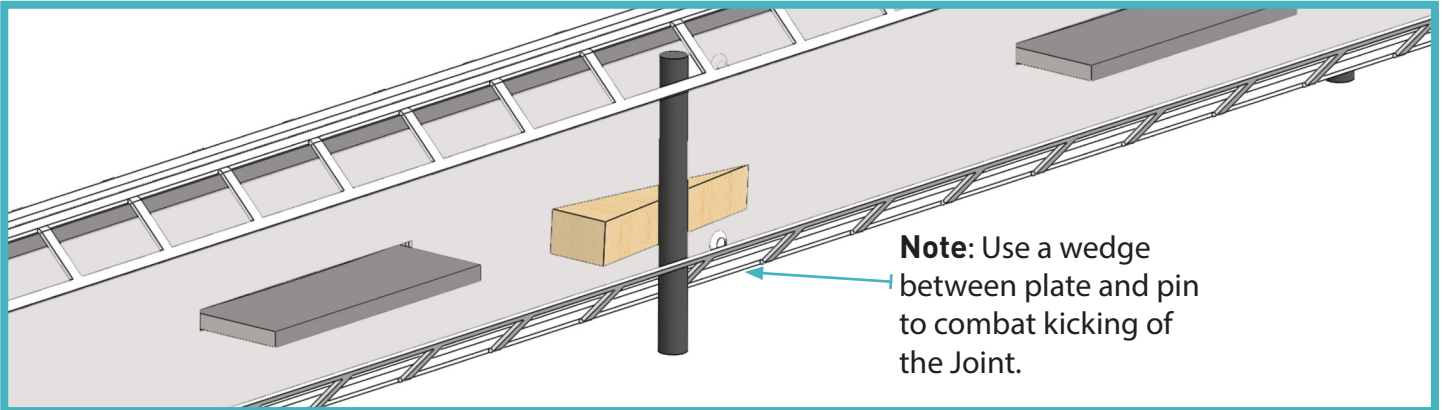

04 Vibrate Concrete

After the concrete is set, remove the AlphaFix and the AlphaFix end. Poker vibrate along length of the Joint to compacted concrete.

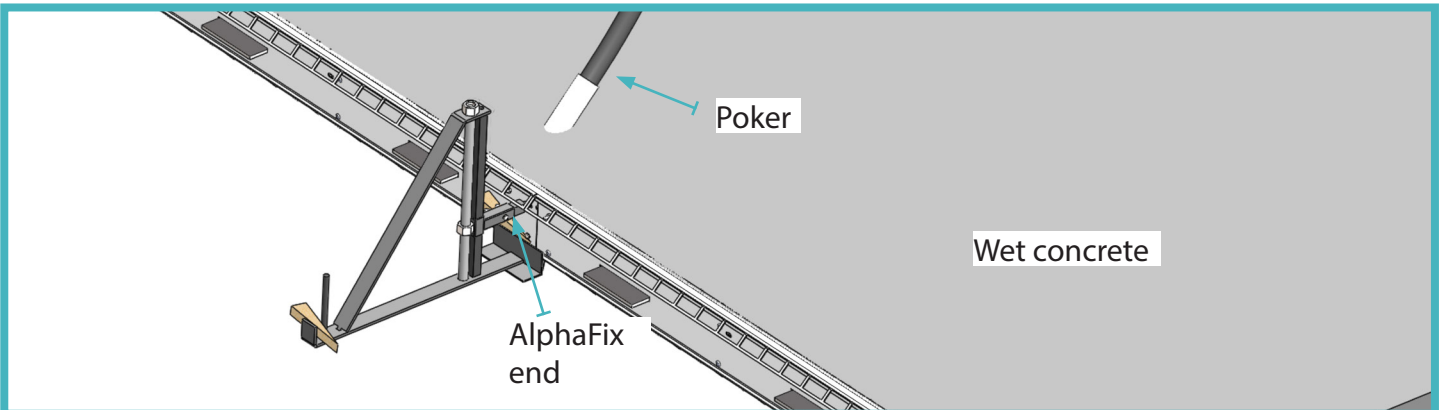

05 Finish

Finish concrete, flush to top of the Joint ensuring the rail is clearly visible. Before next side is cast, cut Joints support pins.