

Signature Installation Guide

Using AlphaFix Method

Installation Guide Issue V1.0
14/07/22

01 Placing the Signature Joint

Place first length of Signature Joint on the ground in an upright position. The Joint has a this way up sticker on it. But if that is missing, the top of the Joint has rebar either side of the Joint 30mm from the top.

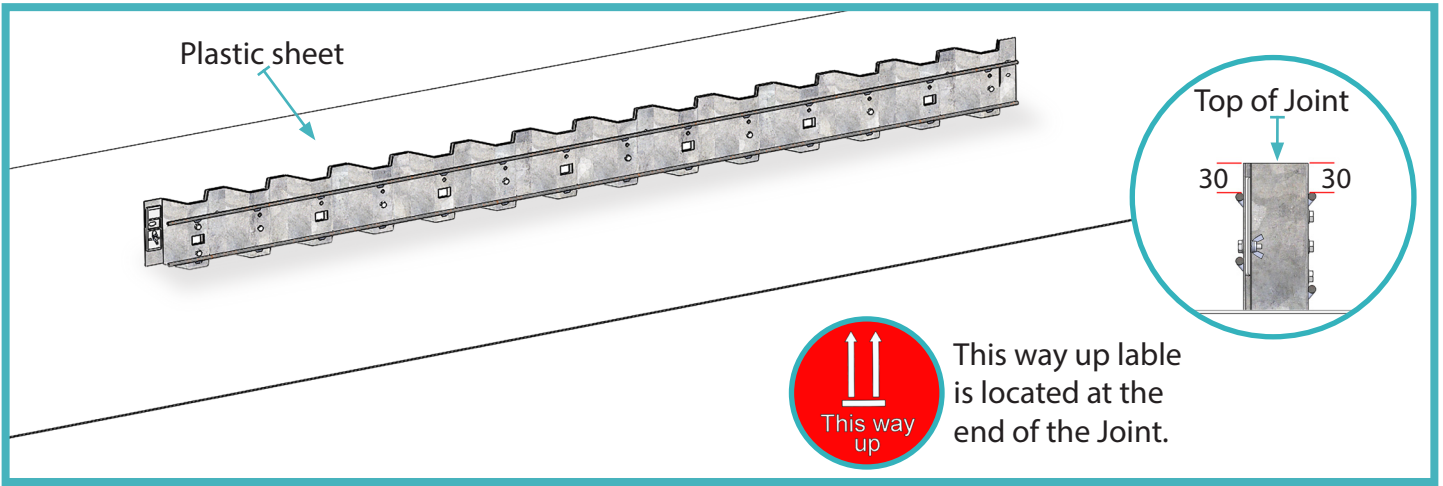

02 Assemble dowel to the Joint

Insert dowel bar fully through the rectangle slot and ensure the sleeve is in contact with the Joint. Secure the dowel in place using the red plastic clips provided.

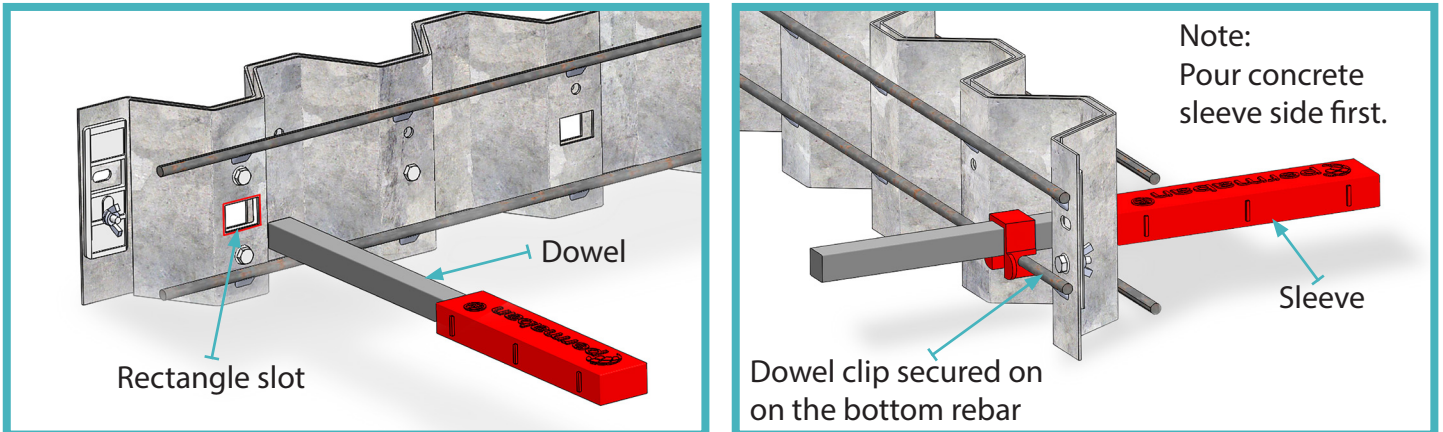

Signature Installation Guide

Using AlphaFix Method

Installation Guide Issue V1.0
14/07/22

03 Adjust to Height

Ensure Joint is straight and follows the stringline. check the Joint is level, using the spirit level. Also check the height, add wedges and adjust when necessary.

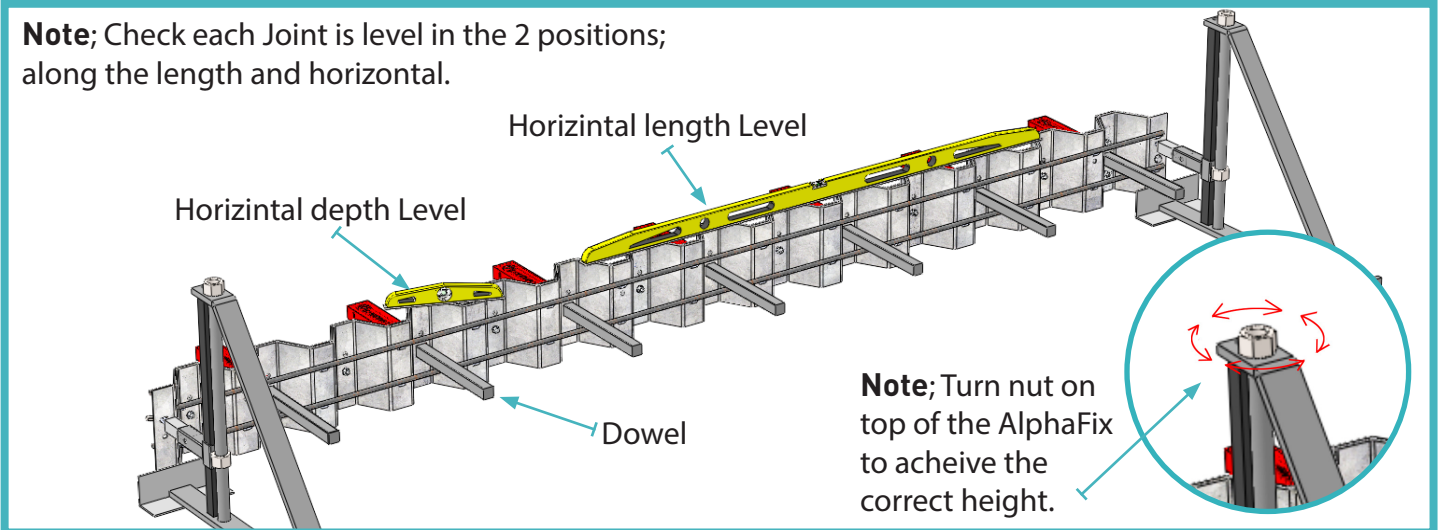
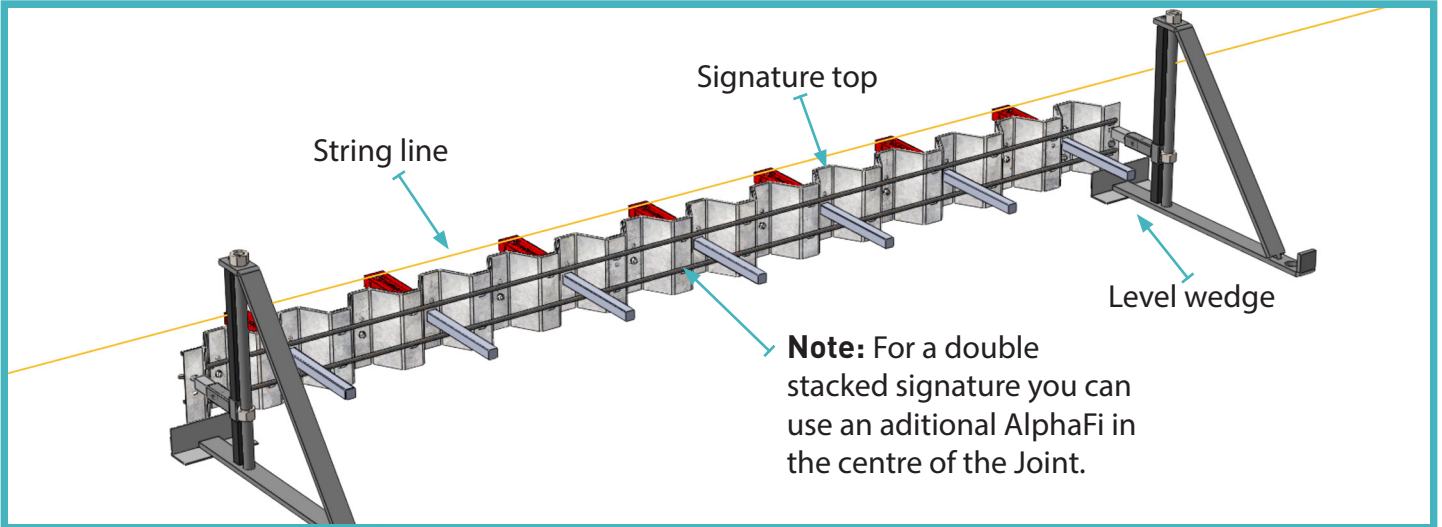

Once Joints are level hammer pins can be used for extra support.

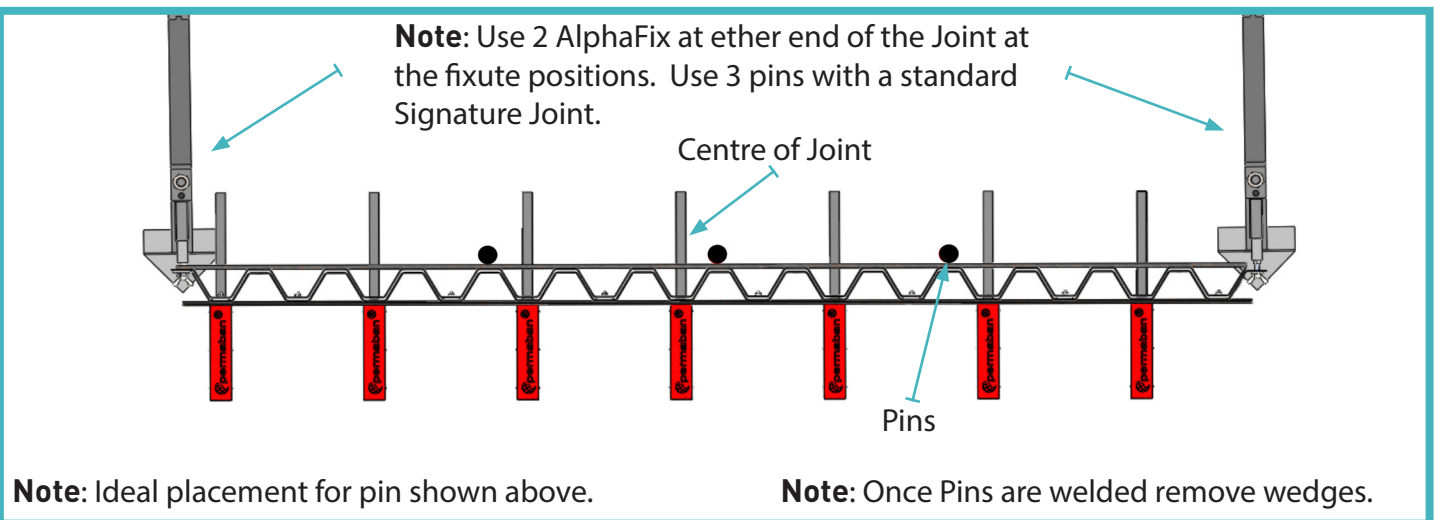

Signature Wave Installation Guide

Using AlphaFix Method

Installation Guide Issue V1.0
14/07/22

04 Position the second length

Insert AlphaFix through the fixture ends of the Joints

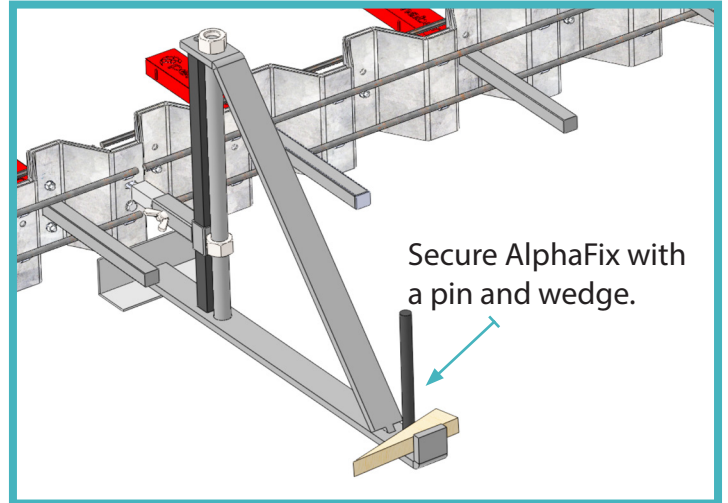
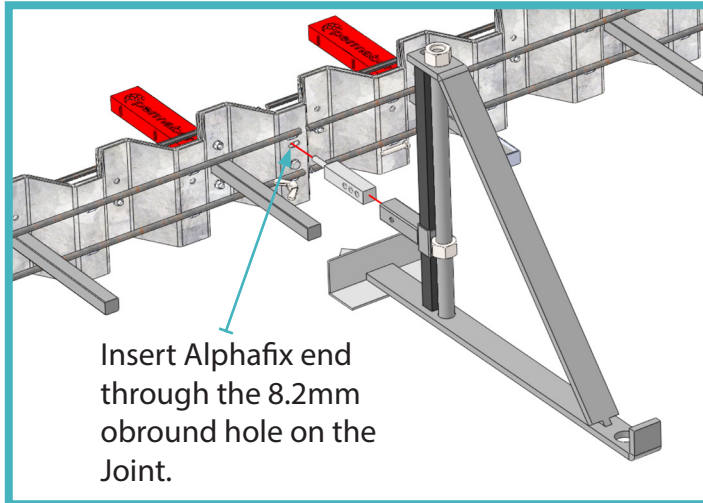

05 Vibrate Concrete

Poker vibrate along length of the Joint to compacted concrete.

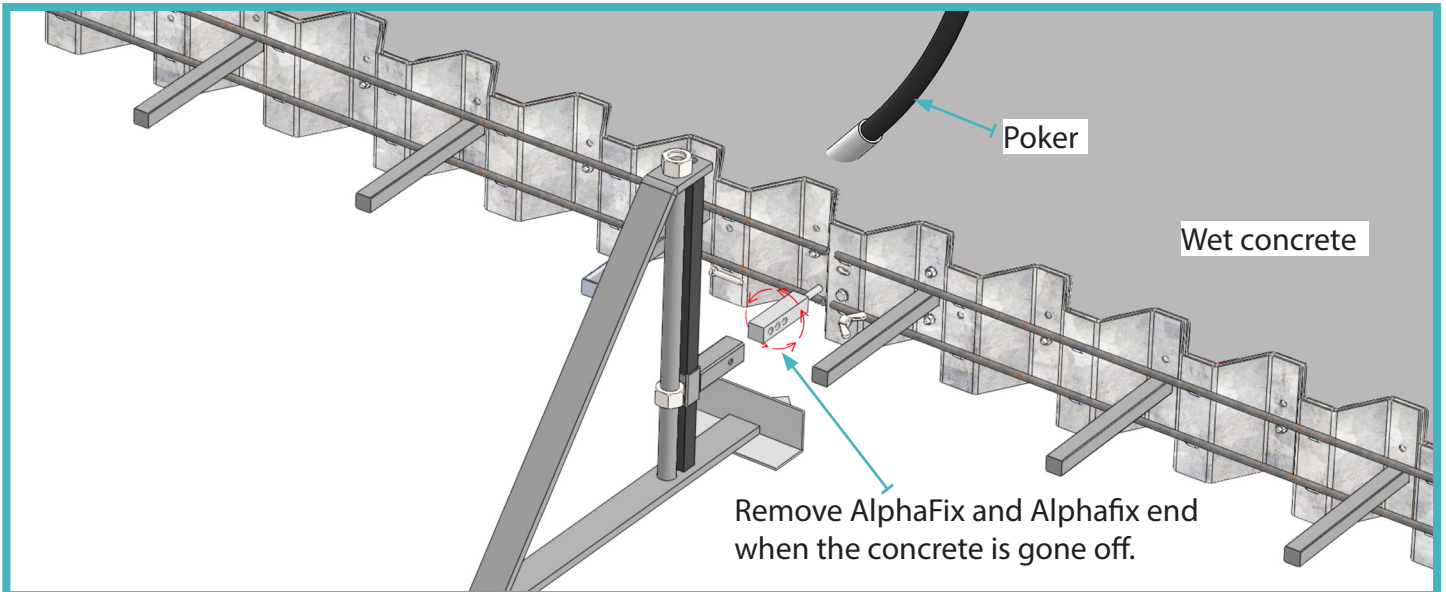

06 Finish

Finish concrete, flush to top of the Joint ensuring the rail is clearly visible.