

Signature Installation Guide

Using Pin and Weld Method

Installation Guide Issue V1.0
14/07/22

01 Placing the Signature Joint

Place first length of Signature Joint on the ground in an upright position. The Joint has a this way up sticker on it. But if that is missing, the top of the Joint has rebar either side of the Joint 30mm from the top.

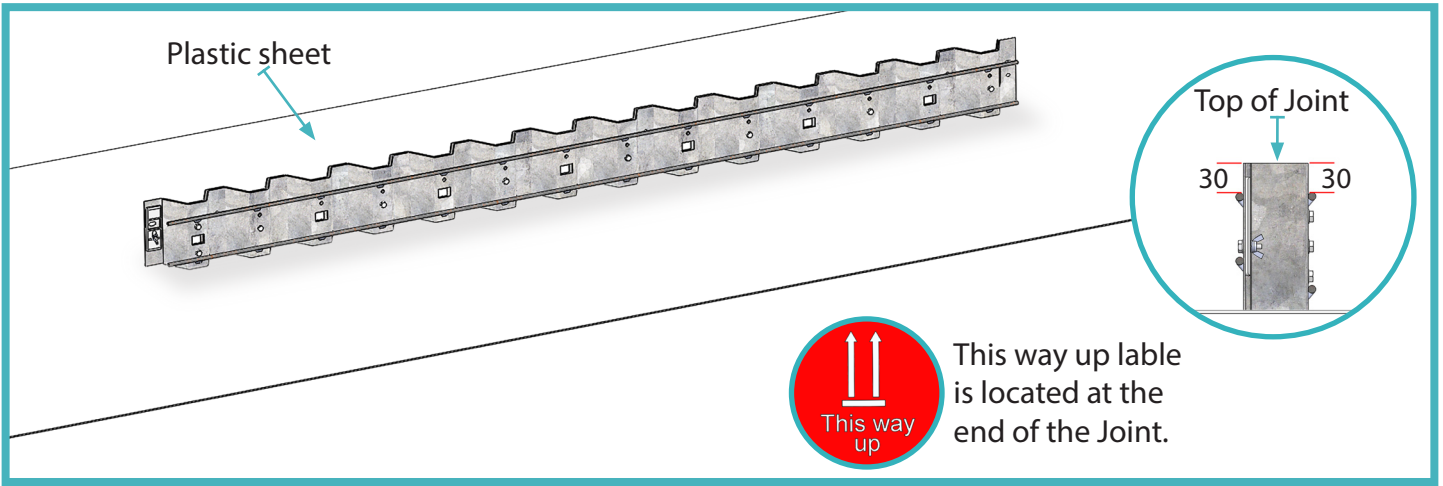

02 Assemble dowel to the Joint

Insert dowel bar fully through the rectangle slot and ensure the sleeve is in contact with the Joint. Secure the dowel in place using the red plastic clips provided.

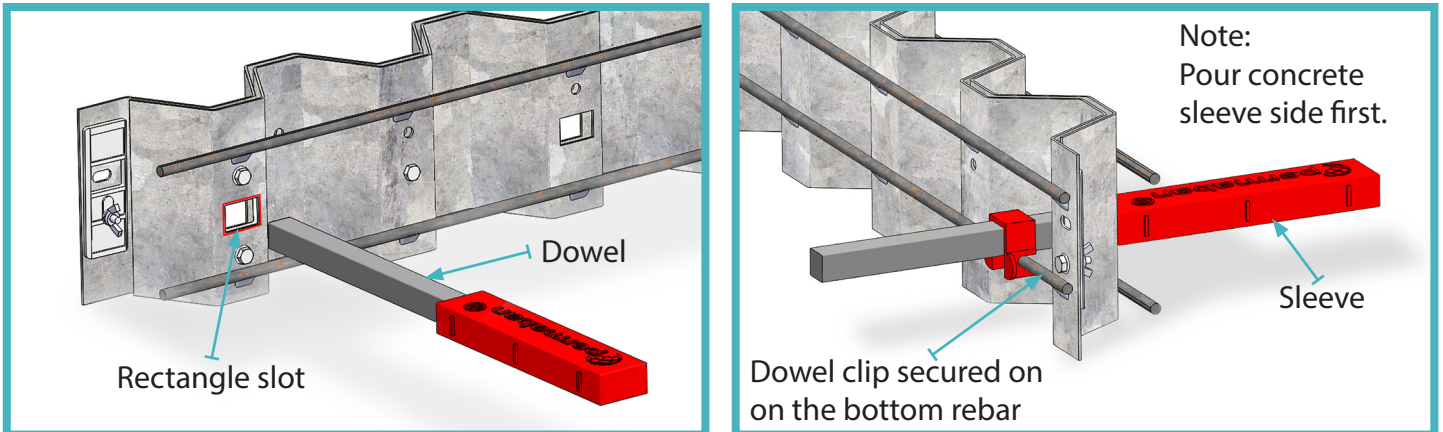

Signature Installation Guide

Using Pin and Weld Method

Installation Guide Issue V1.0
14/07/22

03 Adjust to Height

Ensure Joint is straight and follows the stringline. check the Joint is level, using the spirit level. Also check the height, add wedges and adjust when necessary.

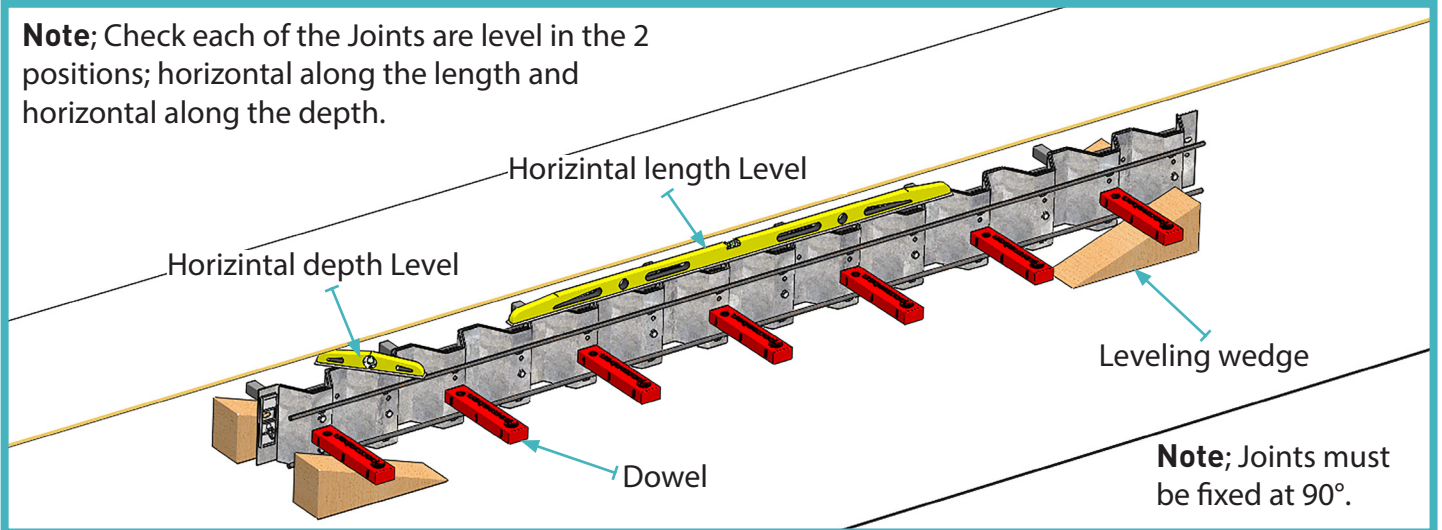
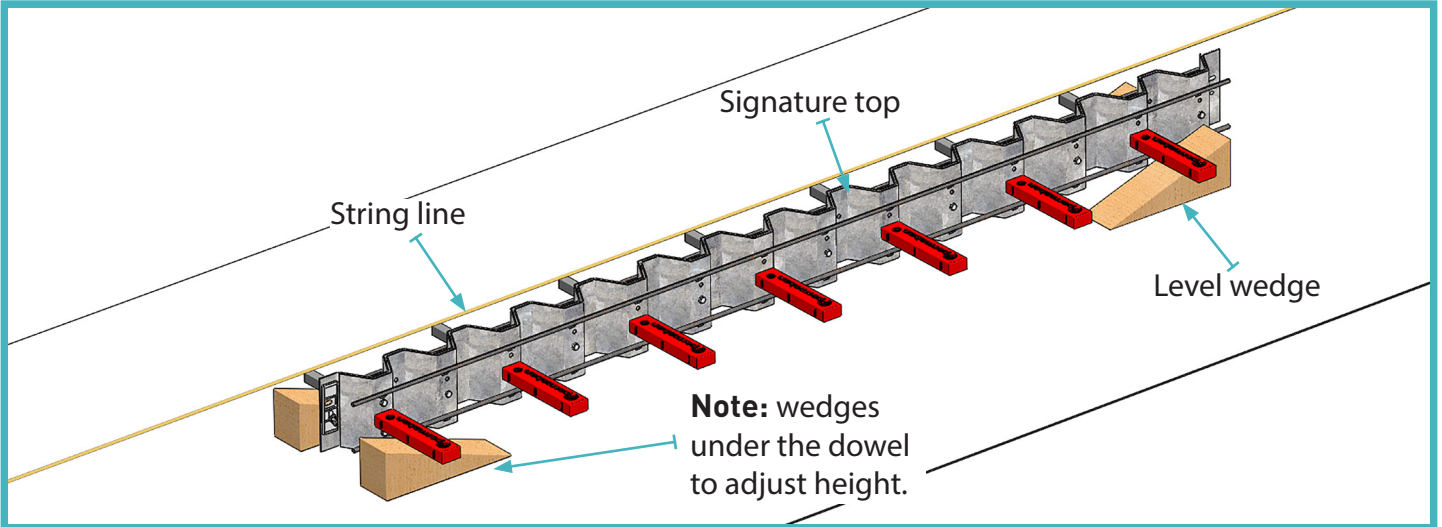

Once Joints are level hammer pins ether side of the Joint and tack weld them to the rebar.

Note: Use 4-6 pins with a standard Signature Joint.
Use 8 pins when Installing a double stacked Signature joint.

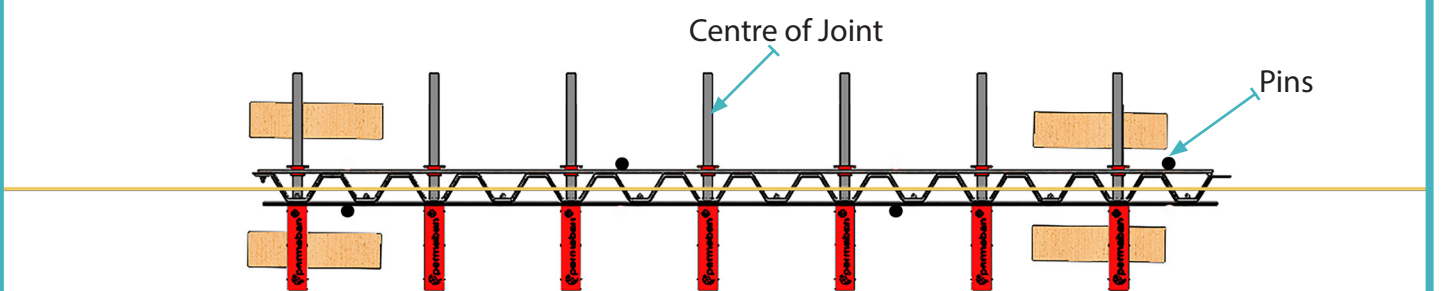

Note: Ideal placement for pin shown above.

Note: Once Pins are welded remove wedges.

Signature Wave Installation Guide

Using Pin and Weld Method

Installation Guide Issue V1.0
14/07/22

04 Position the second length

Support the next Joint with wedges and fasten the 5mm spacer end with the previous Joint. Repeat 4,5 and 6 until run of Joints is complete.

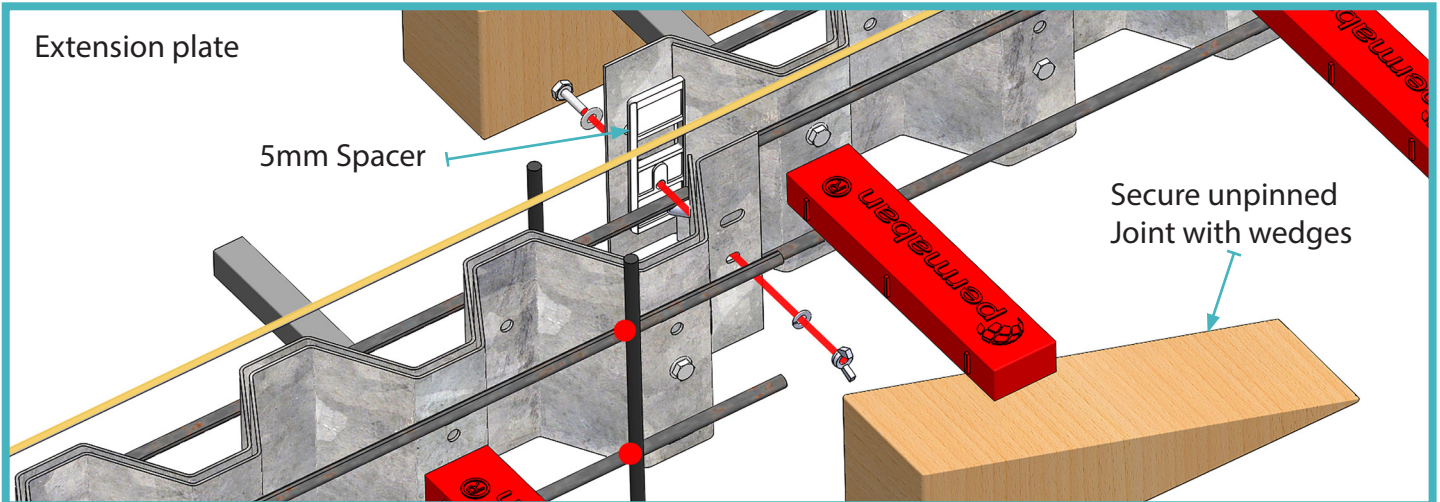

05 Vibrate Concrete

Poker vibrate along length of the Joint to compacted concrete.

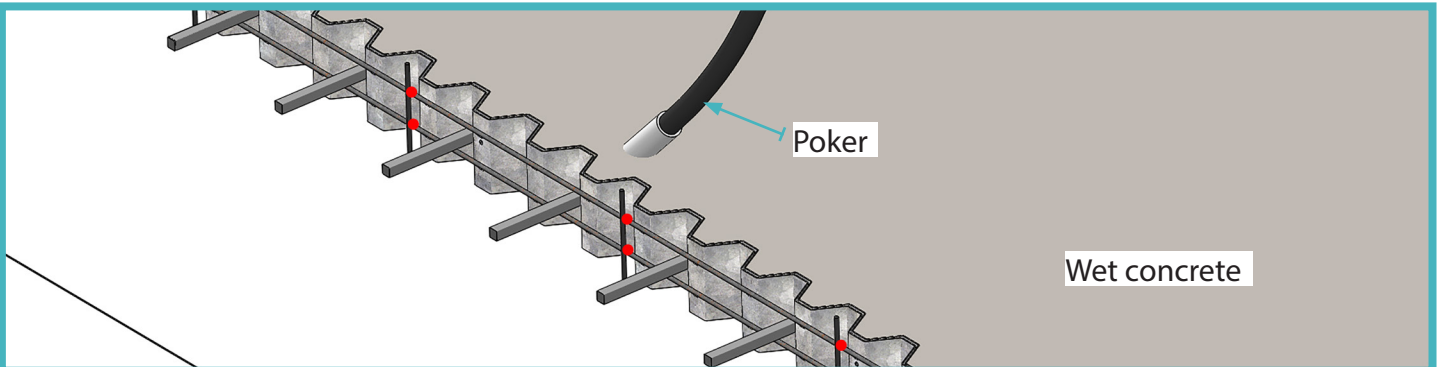

06 Finish

Finish concrete, flush to top of the Joint ensuring the rail is clearly visible.