

## Permaban Signature Slide Guide Using Alpha Feet

Installation Guide Issue V1.0  
14/07/22

### 01 Placing the Wave Joint

Place Joints on the floor with 6mm Top face pointing up.

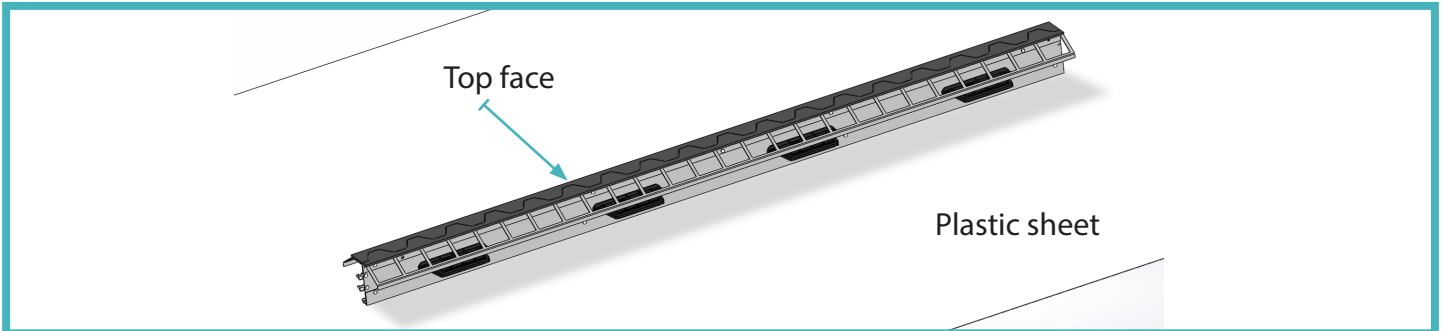

### 02 Set Up

Flip the Joint to insert the Universal foot and stand end to end, temporarily remove M6 end fixtures, push Joints together and re-assemble M6 fixtures through the vacant assembly holes.

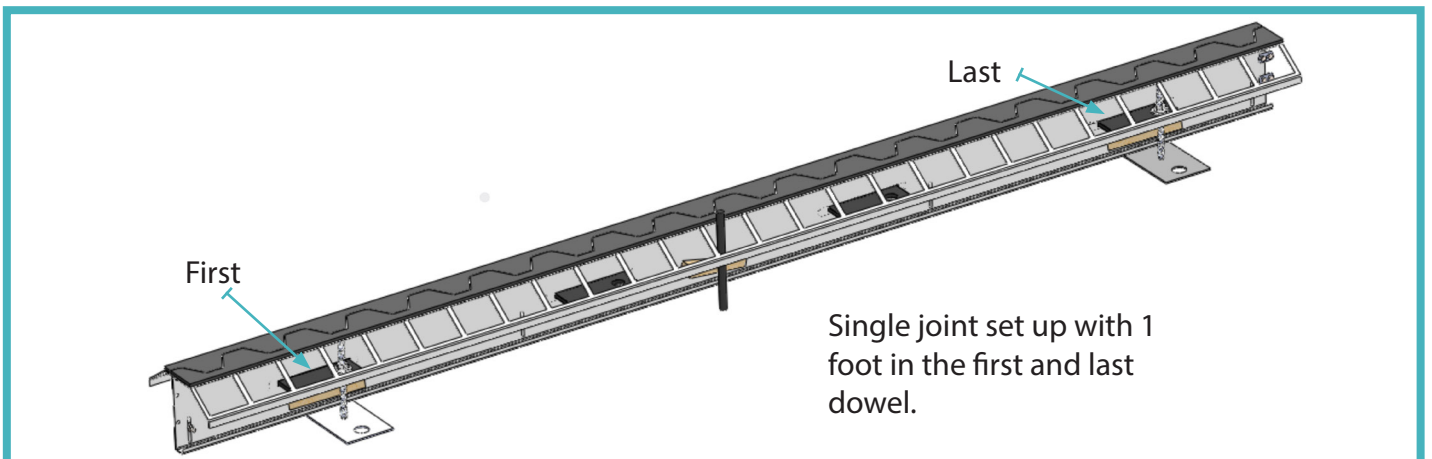
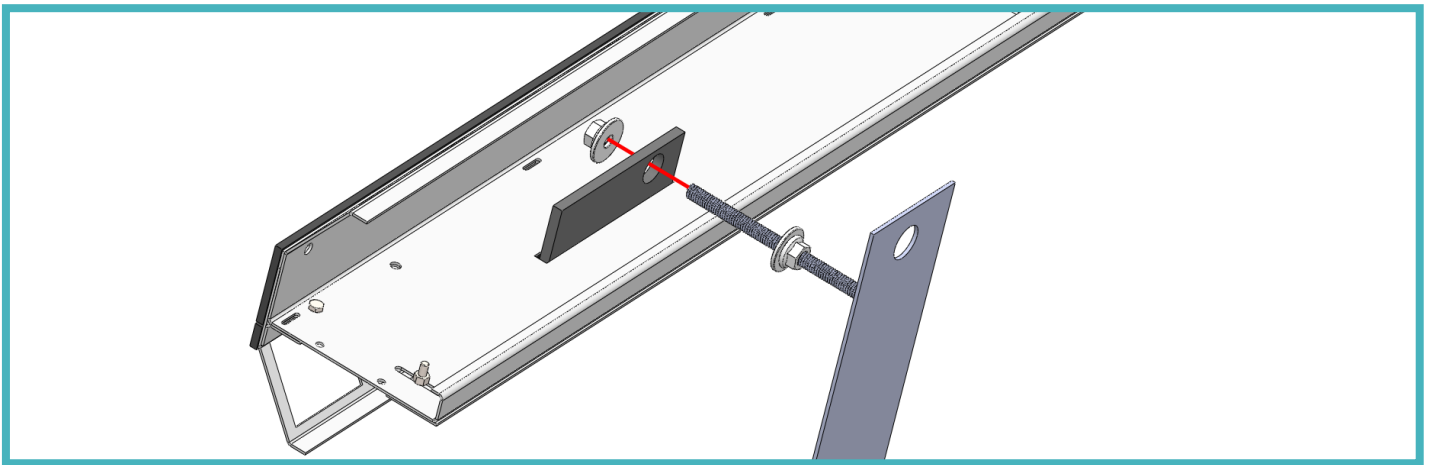

# Permaban Signature Slide Installation Guide

## Using Alpha Feet

Installation Guide Issue V1.0  
14/07/22

### 03 Fix Joints together

Soon as the first Joint is set up you can continue to assemble the remaining of the run of Joints.

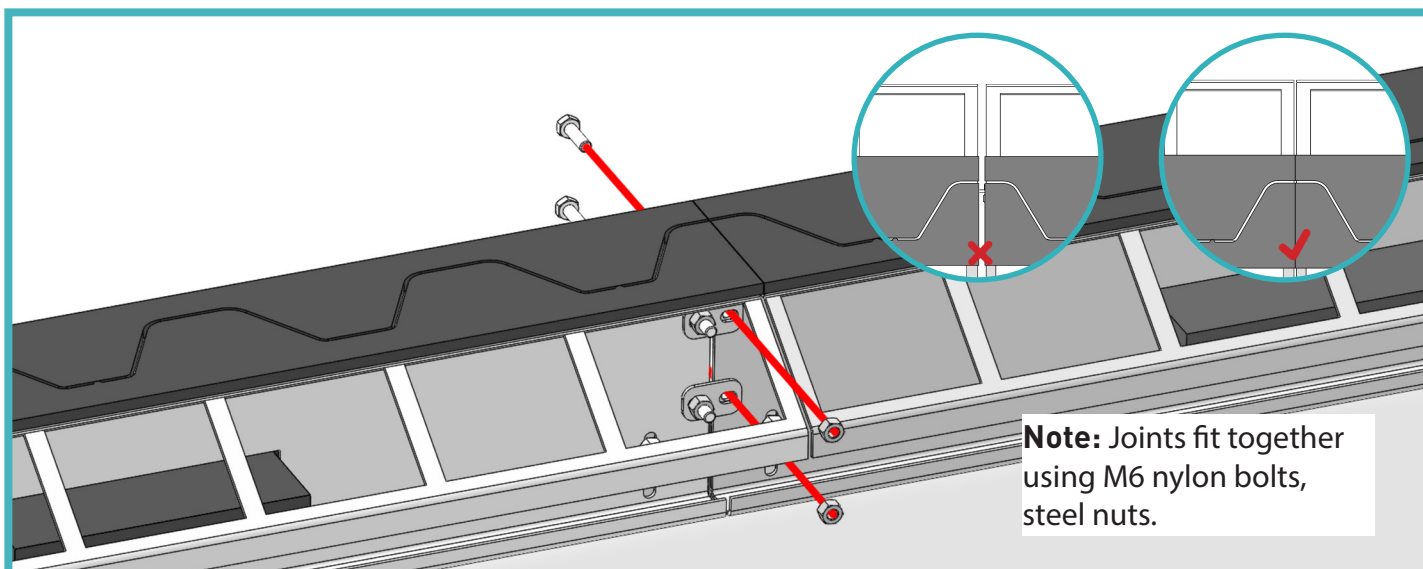
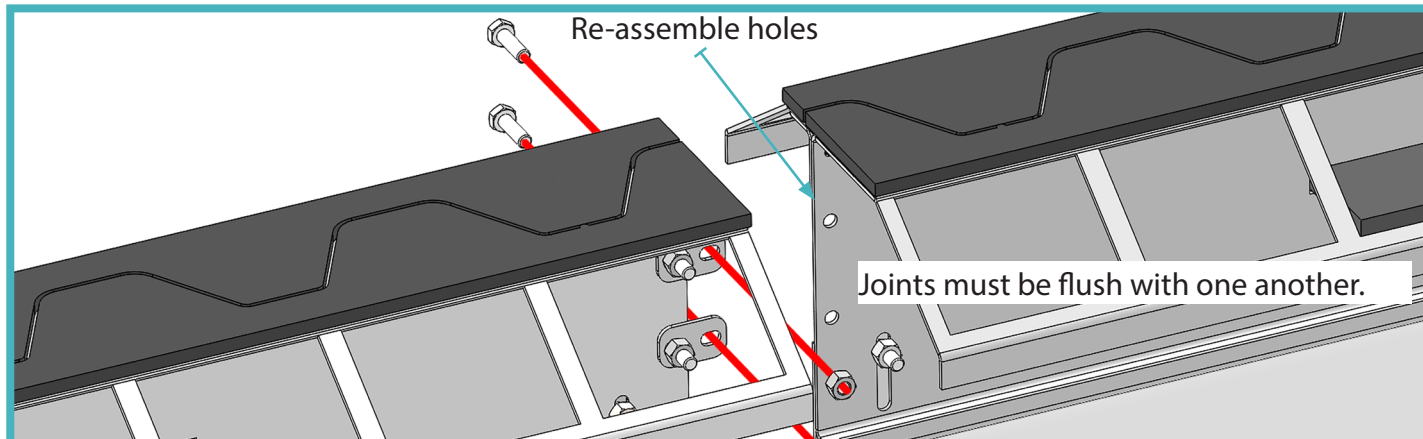

### 04 Adjust to Height

Use the Universal Foot on either side and either end of the Joint to adjust the height. Road form pins and a wedge is then used to help prevent kick in the centre of the Joint.

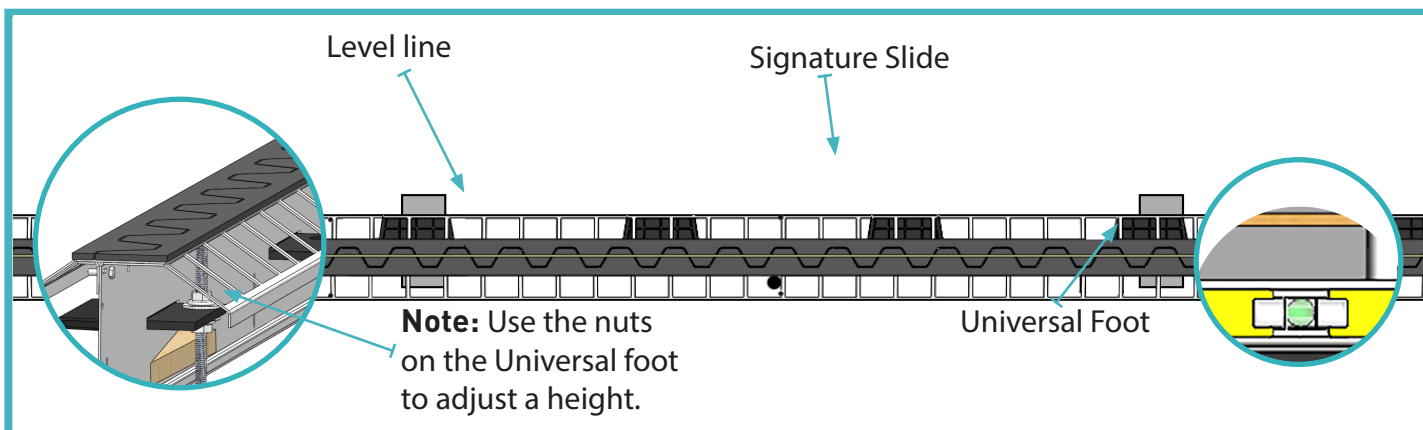

# Permaban Signature slide Installation Guide

## Using Alpha Feet

Installation Guide Issue V1.0  
14/07/22

Measure the horizontal level using the top strip.

**Note;** Joints must be fixed at 90°.

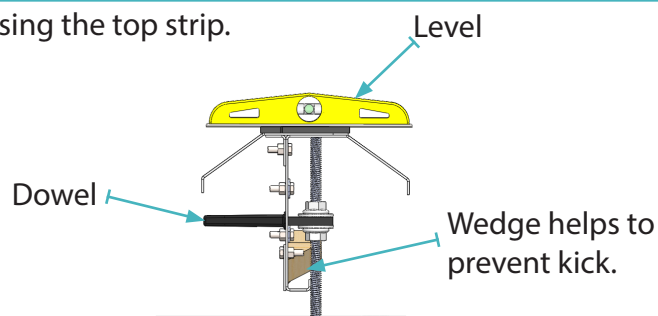

**Note;** Check the Joint is level in the 3 positions.



## 05 Support bars / Wedges

This method used 3 times along the Joint offers good support to the extension plate.

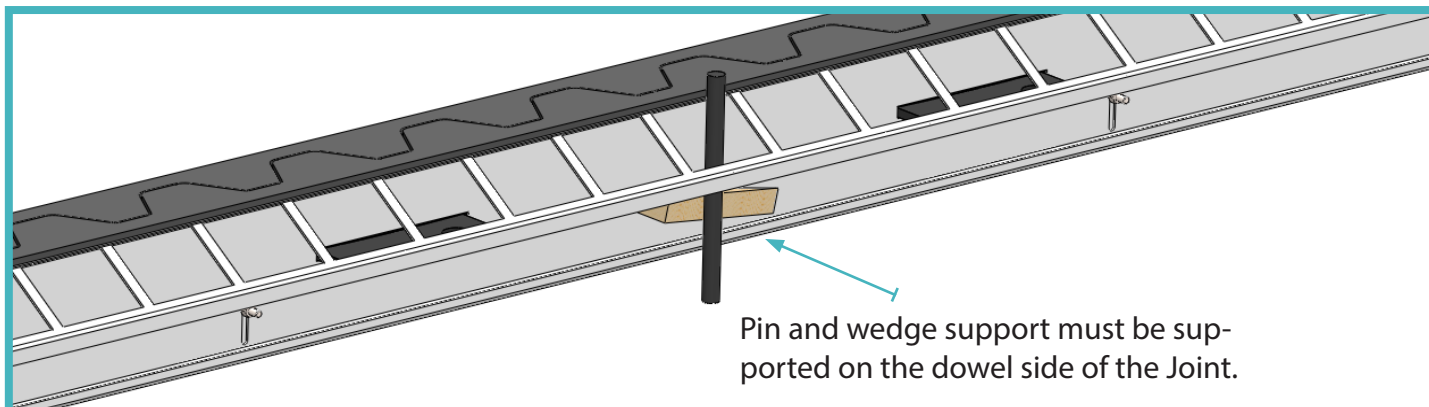

## 06 Vibrate Concrete

Poker vibrate along length of the Joint to compacted concrete.

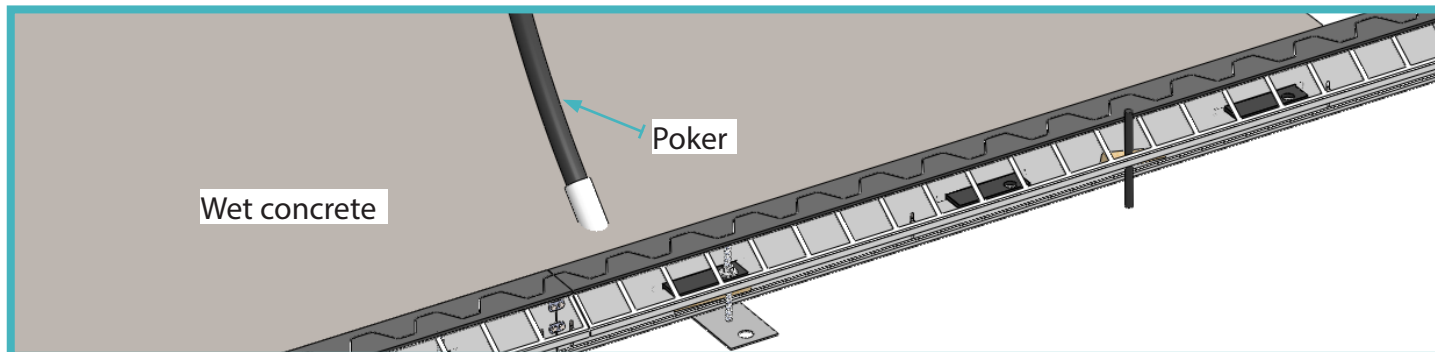

## 07 Finish

Finish concrete, flush to top of the Joint ensuring the rail is clearly visible.