

Permaban Wave Edge

Specification Sheet
Issue 1.0
20/04/2020

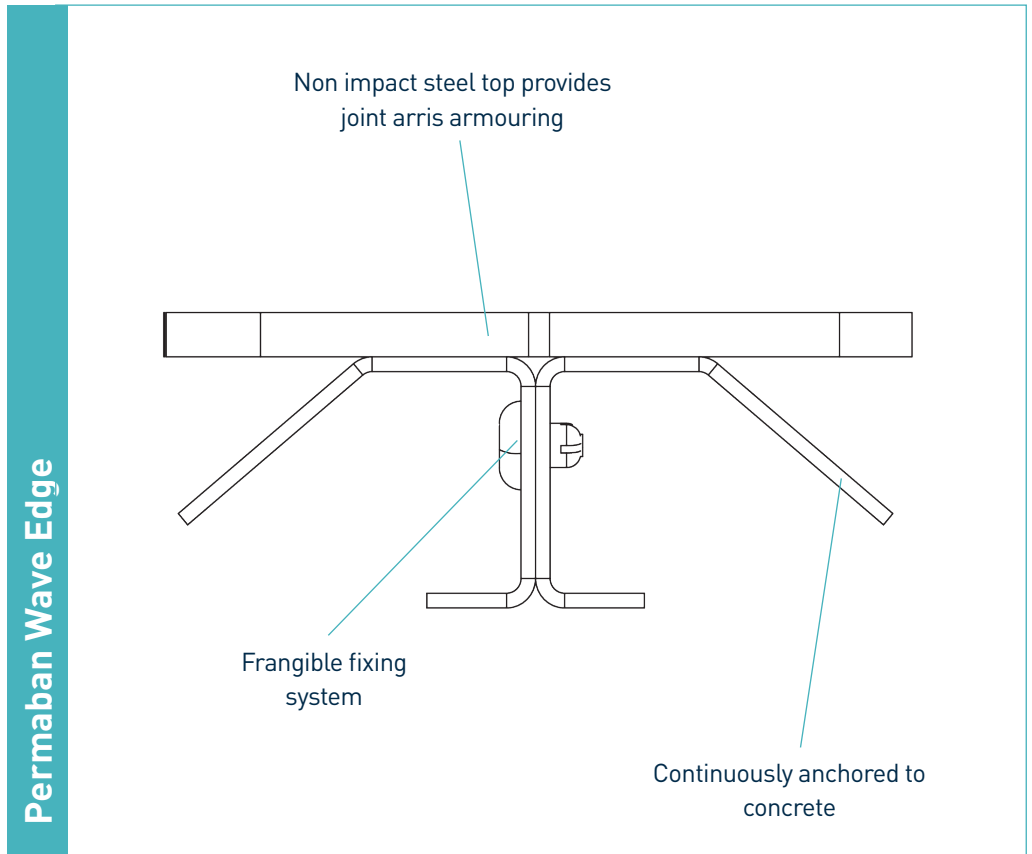
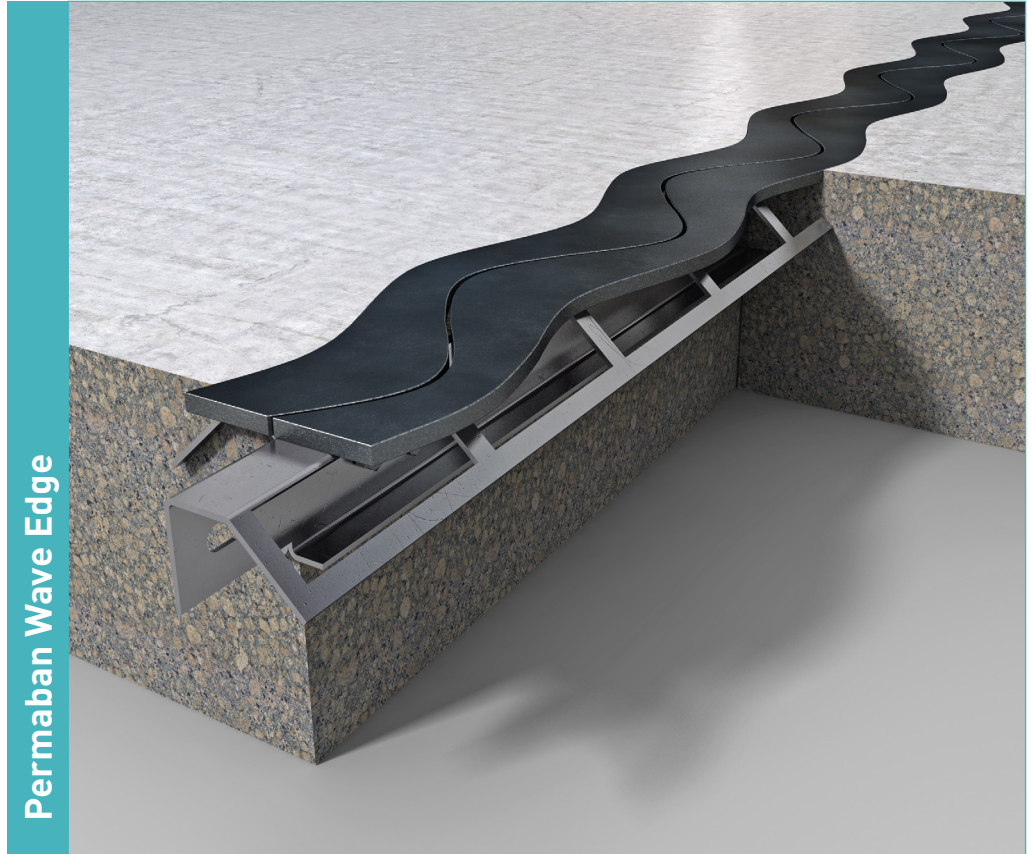

Permaban Wave Edge

Specification Sheet Issue 1.0
20/04/2020

manufacturing tolerances

Length	±2.0mm	Height	±1mm	Straightness	±0.5mm/600mm
---------------	--------	---------------	------	---------------------	--------------

dimensions of Permaban Wave Edge

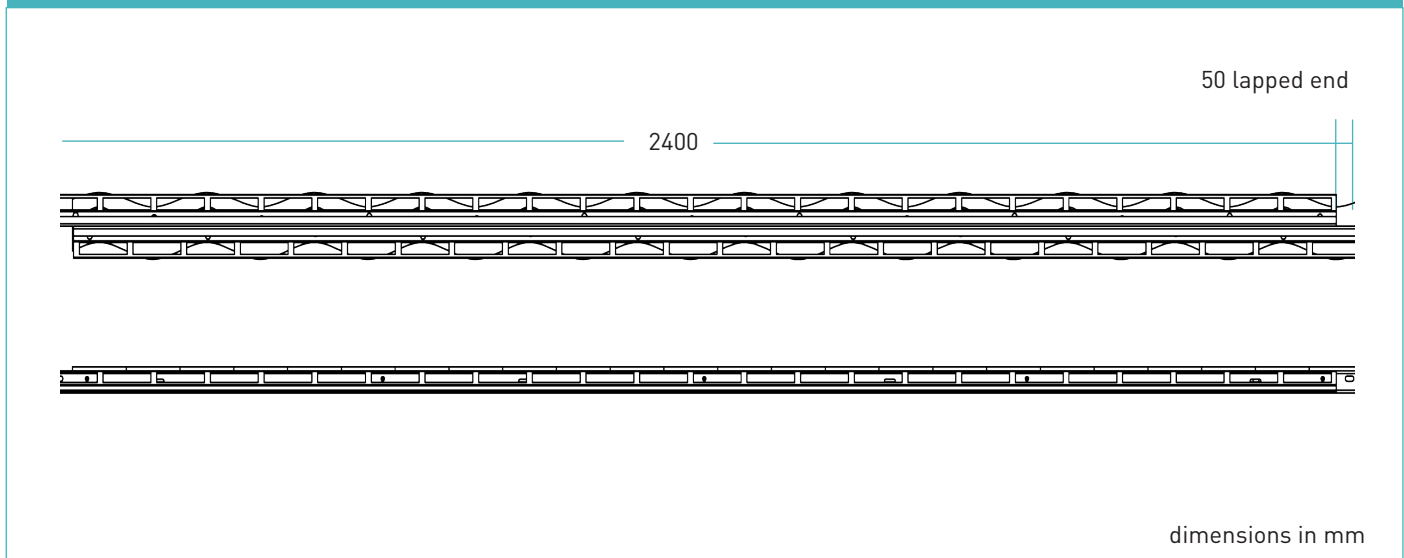

dimensions and weight of Permaban Wave Edge

Joint Height, h (mm)	Length (mm)	Single Joint Weight (kg)	Number Per Bundle	Bundle Weight (kg)
45	2400	14	94	1530

Typical height and length values shown only. Weight values shown are approximate.

materials

Component	Material
Joint arris armouring	S275JR EN 10025:2004
Continuous concrete tie	BS EN 1030:2006 DC01