

Permaban Wave Installation Guide

To Suit Slabs 150mm to 200mm Using AlphaFix Method

Installation Guide Issue V1.0
15/04/19

01 Placing the Wave Joint

Place Joints on the floor with sleeves pointing up.

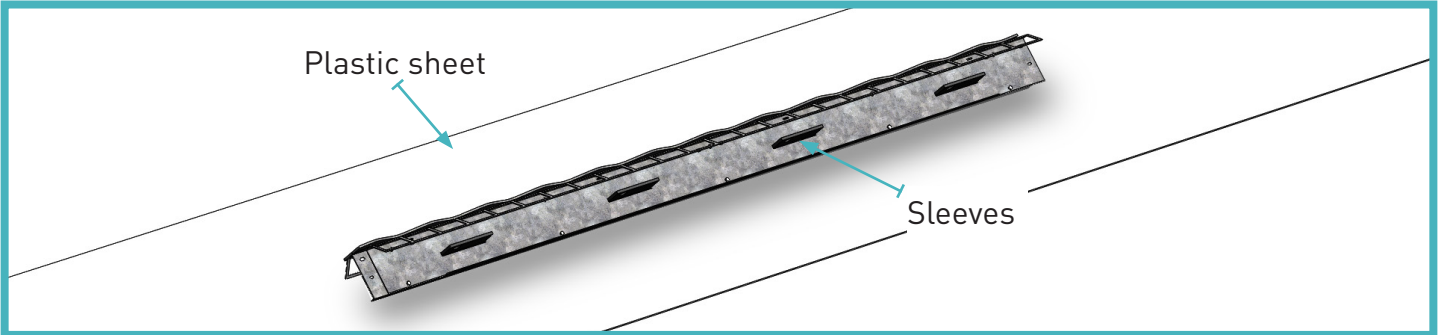

02 Inserting AlphaFix

Place the AlphaFix in position at the start of the Joint, then pick up the Joint and insert it onto the AlphaFix End. Once inserted, place the washer and screw on the M8 wing nut to secure in place.

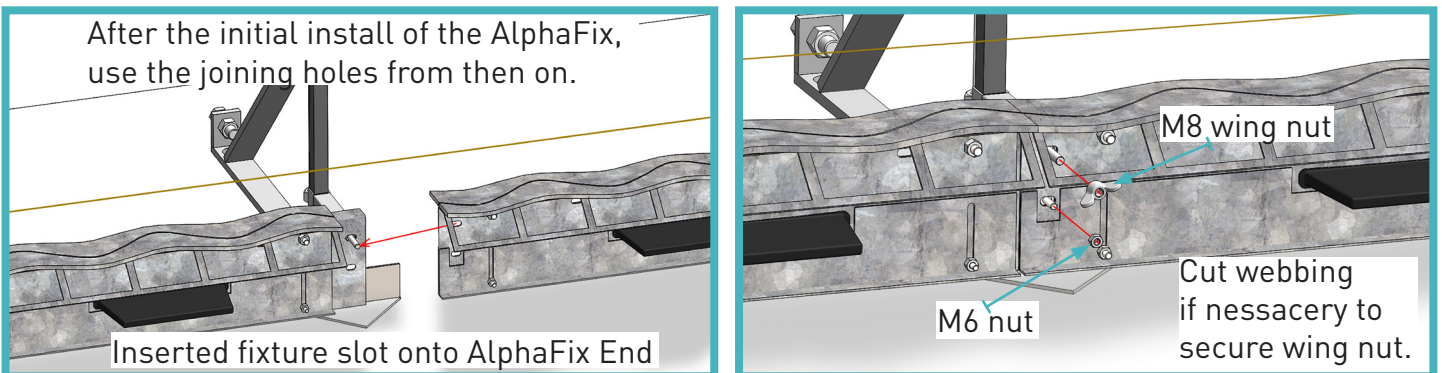
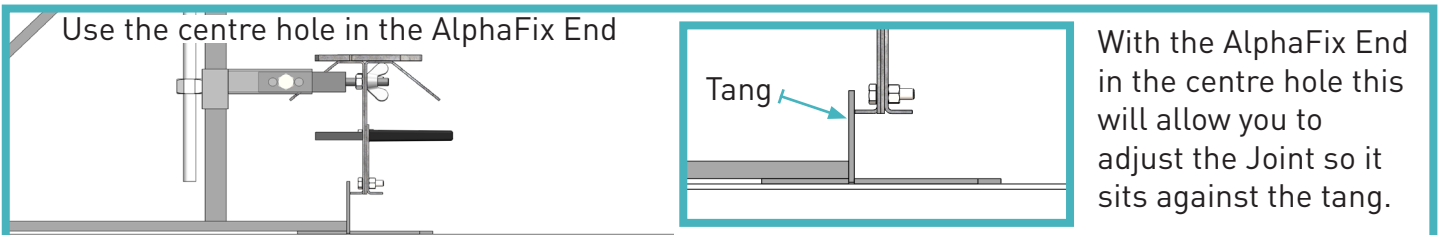
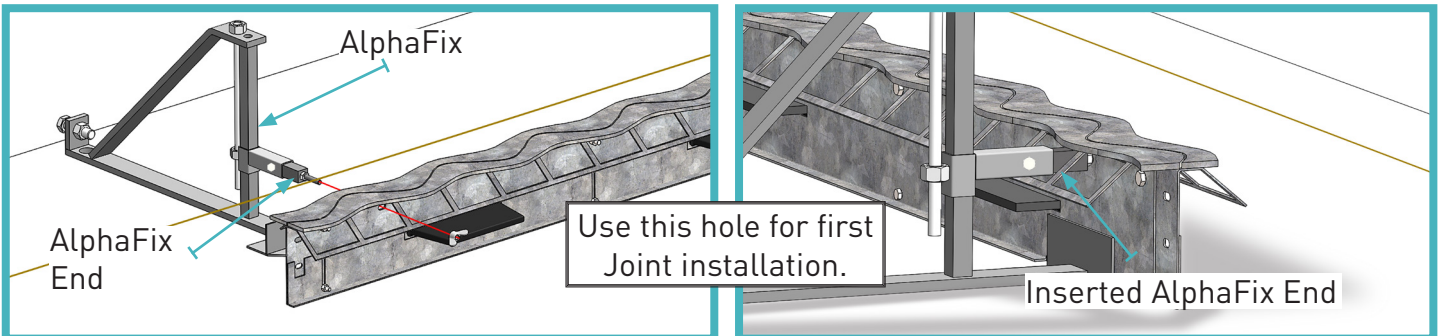

Permaban Wave Installation Guide

To Suit Slabs 150mm to 200mm Using AlphaFix Method

Installation Guide Issue V1.0
15/04/19

03 Adjust to Height

Brace the AlphaFix by using a pin and screwing the M16 bolt tight against it. Adjust the M16 nut on top of the AlphaFix for the required slab depth. Joints must also be pressed together so no gaps are visible.

Joints must be flush with one another.

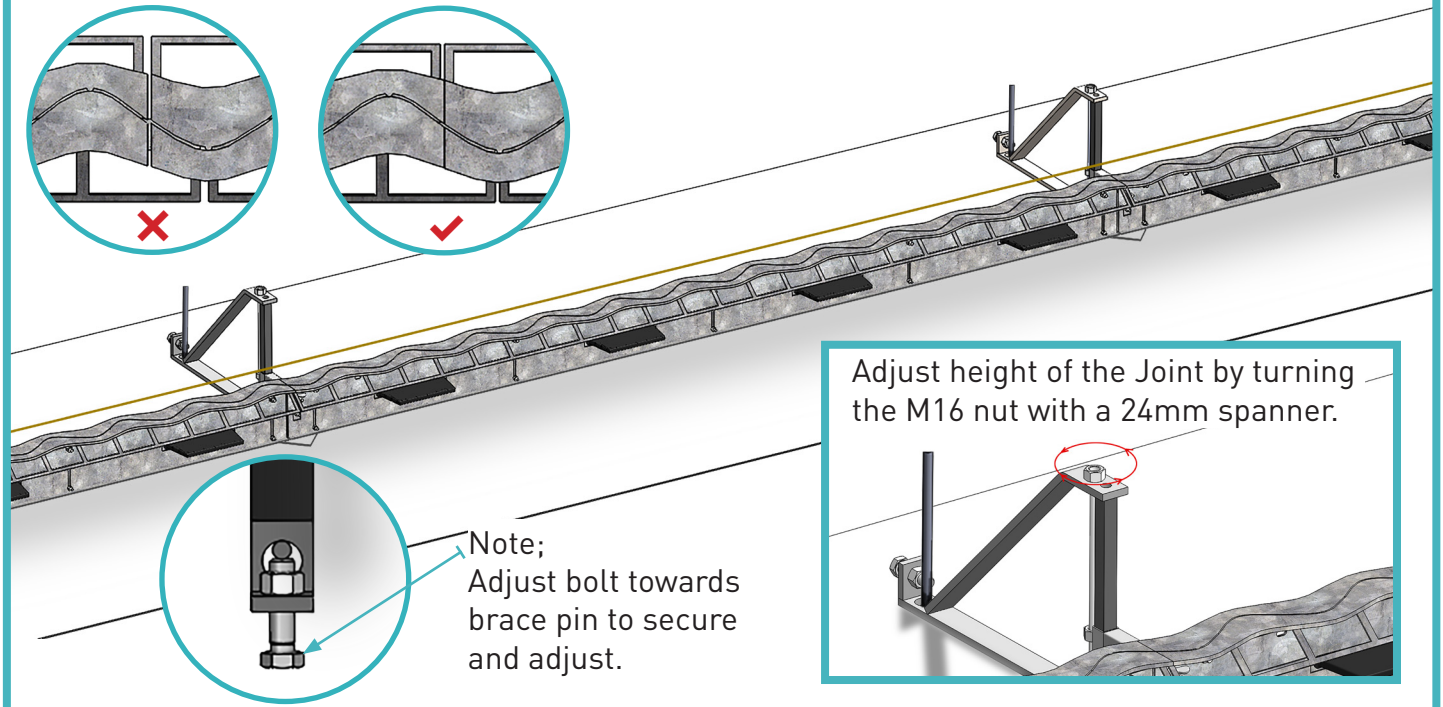
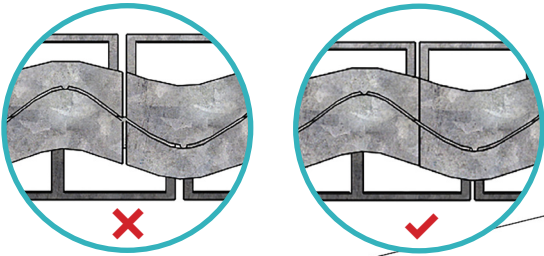

Adjust height of the Joint by turning the M16 nut with a 24mm spanner.

Note;
Adjust bolt towards
brace pin to secure
and adjust.

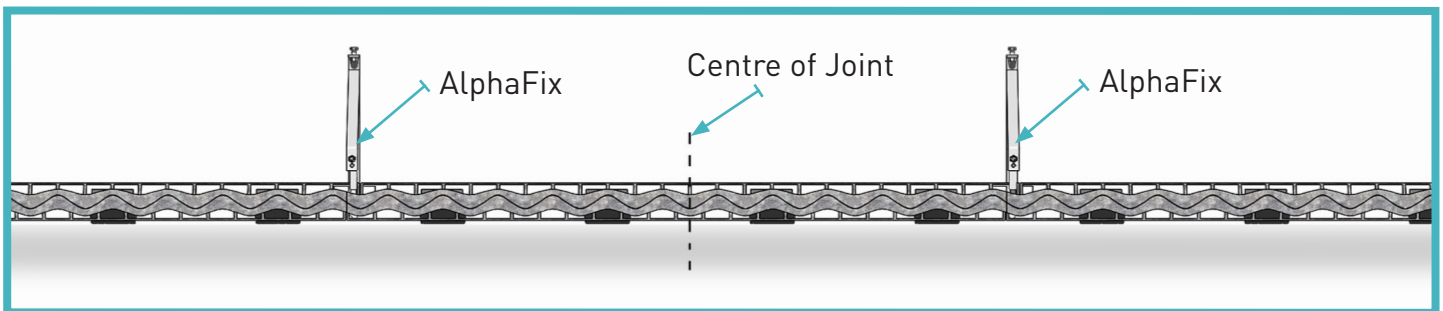

Check the level of the Joints with an optical leveler in three positions below.

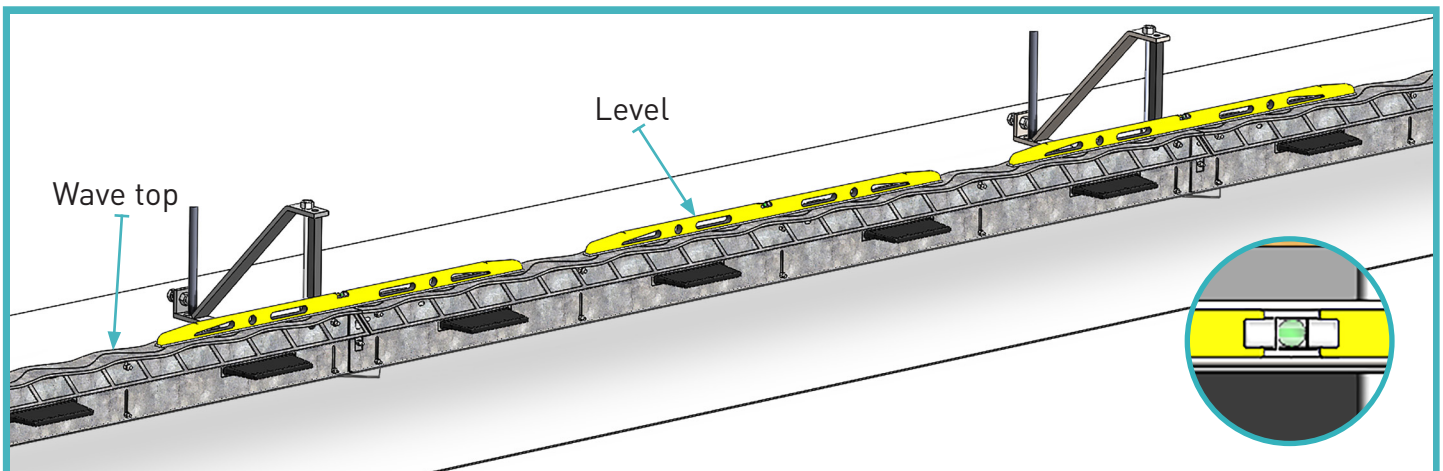

Permaban Wave Installation Guide

To Suit Slabs 150mm to 200mm Using AlphaFix Method

Installation Guide Issue V1.0
15/04/19

Measure the horizontal level using the top strip.

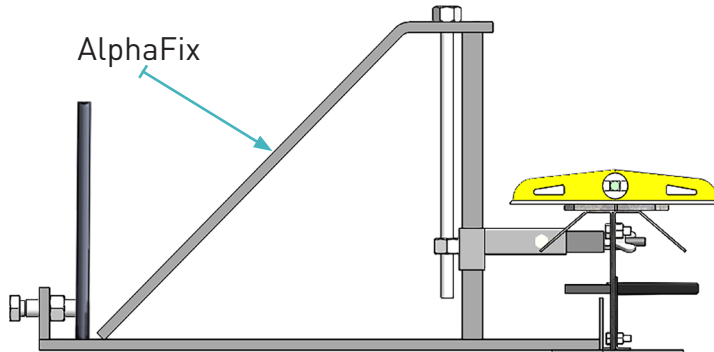

Note; Joints must be fixed at 90°.

04 Adjust Wave extension divider plate

Losen the Nuts on the extension plate then tighten to set the Joint at a specific height.

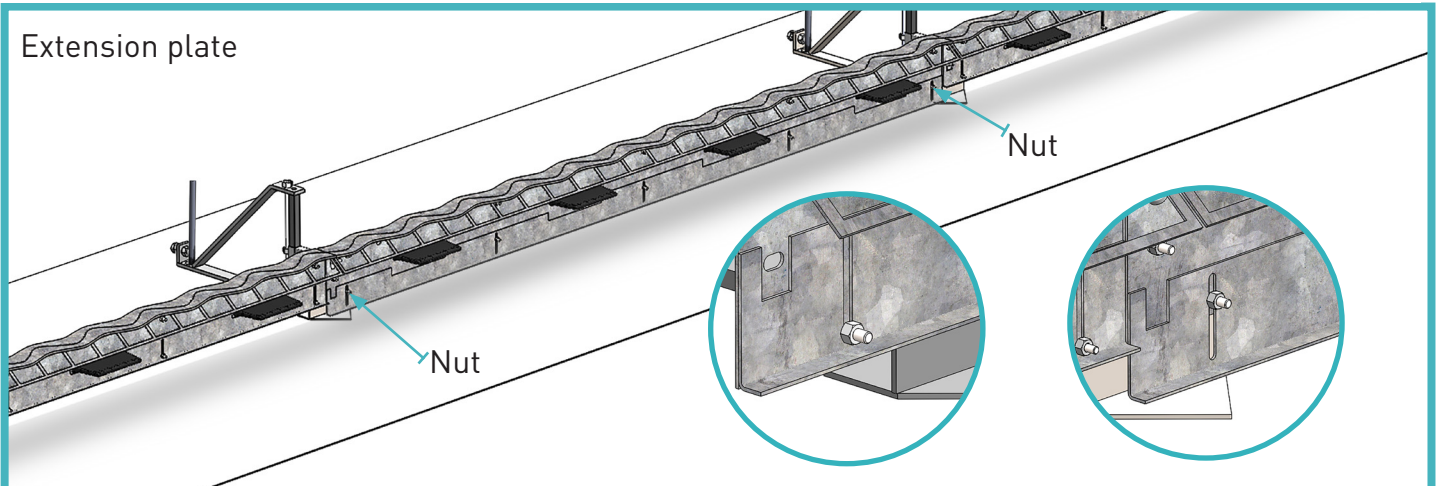

05 Support bars / Wedges

This method used 2 times along the Joint gives good support to the extension plate.

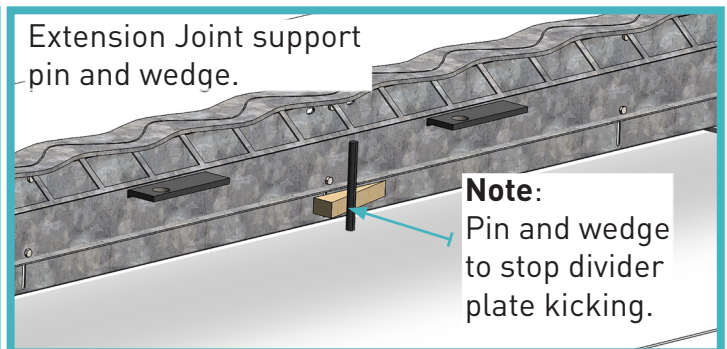
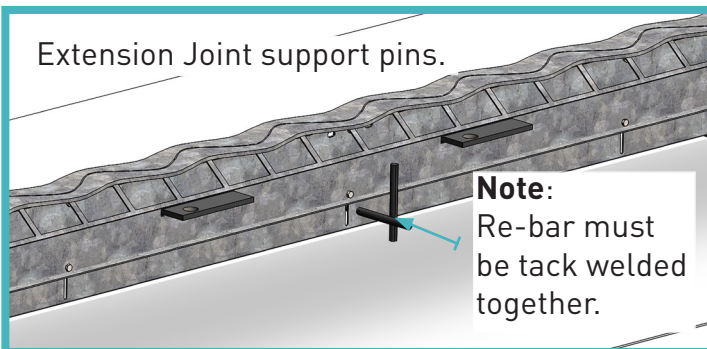

Permaban Wave Installation Guide

To Suit Slabs 150mm to 200mm Using AlphaFix Method

Installation Guide Issue V1.0
15/04/19

06 Vibrate Concrete

Poker vibrate along length of the joint to compacted concrete.

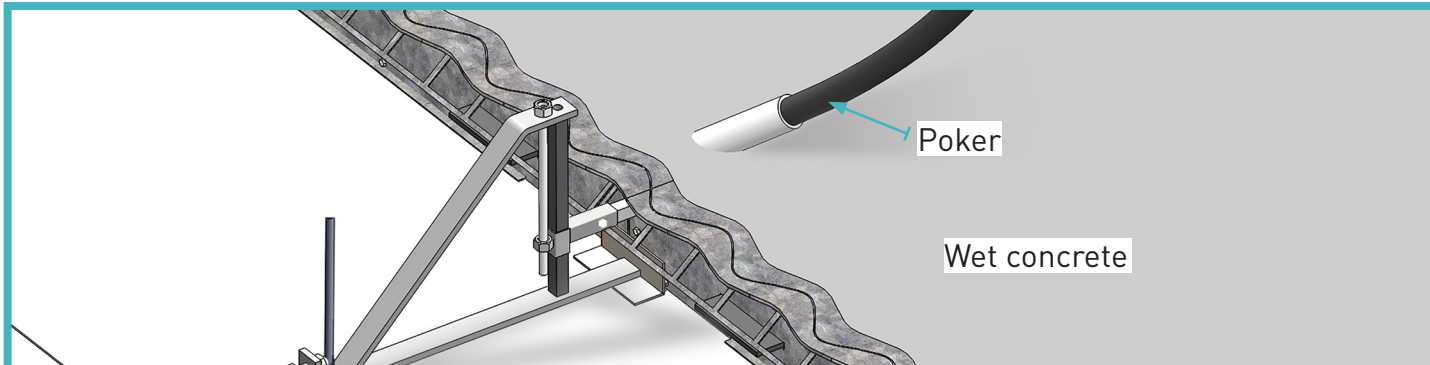

07 Remove AlphaFix

Once the concrete is set, remove AlphaFix body from the AlphaFix End by unscrewing bolt through the 20x20 box. Then unscrew the AlphaFix End from the joint.

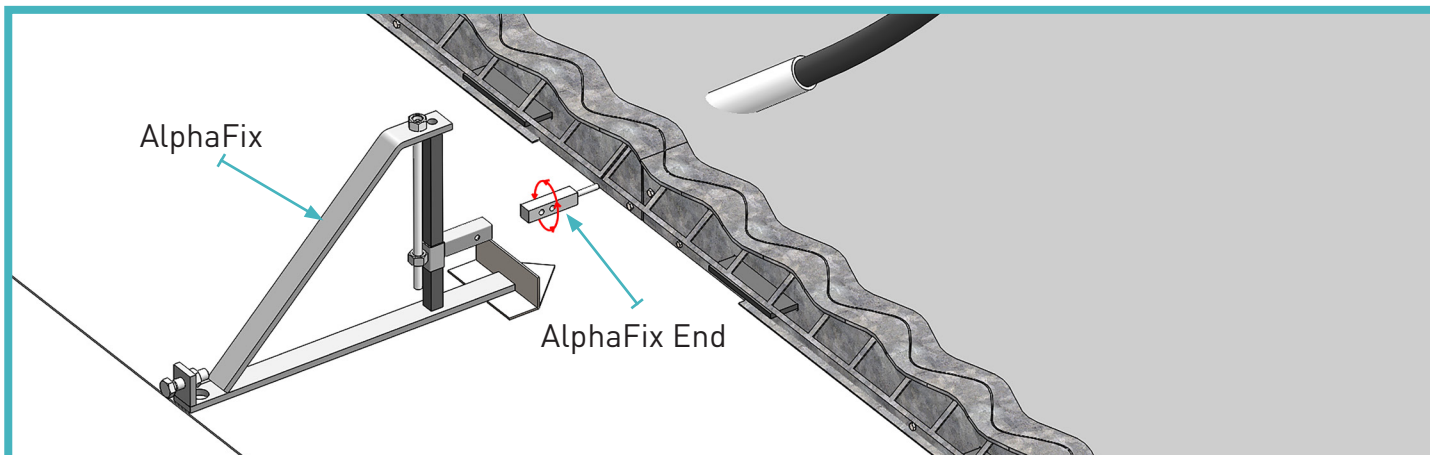

07 Finish

Finish concrete, flush to top of the armoured Joint ensuring the rail is clearly viable.