

Permaban Wave Installation Guide

Using Pin and Weld Method

Installation Guide Issue V1.0
14/07/22

01 Placing the Wave Joint

Place Joints on the floor with dowels pointing down.

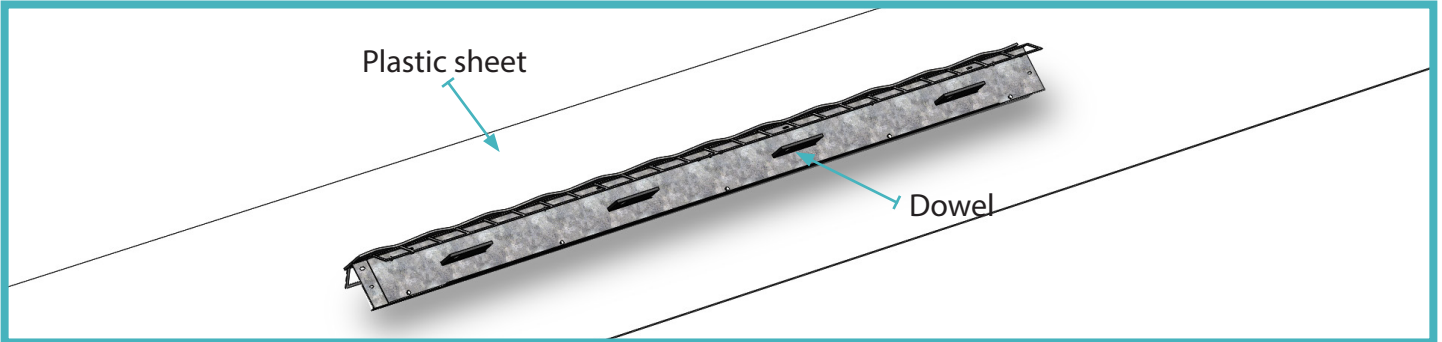

02 Set up

Drive pins through the webbing and tack weld into position.

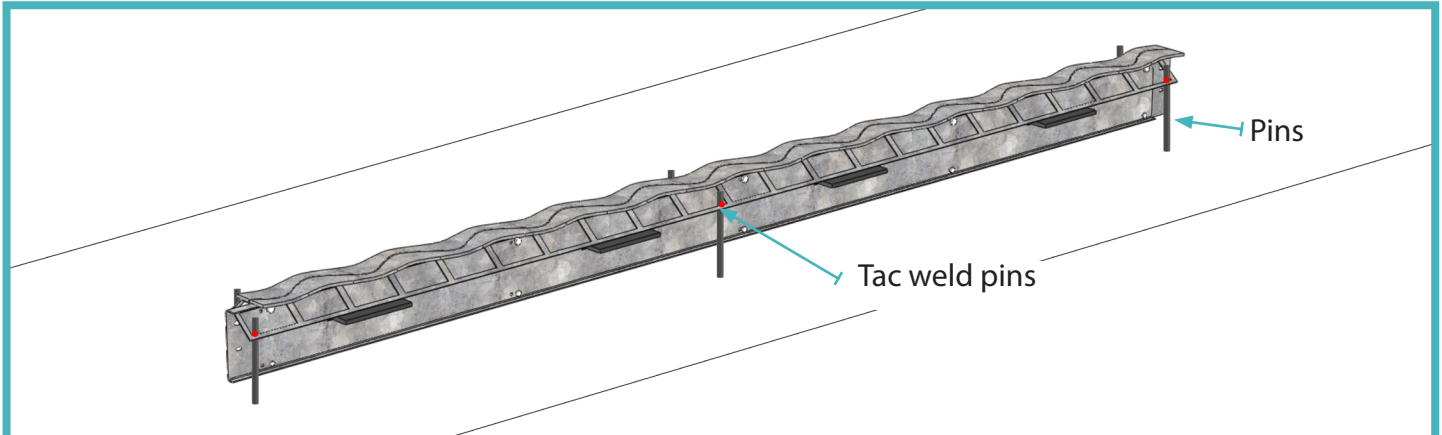

03 Adjust to Height

Use wedges on either side and either end, these are used to adjust the height of the Joint. Road form pins are then driven in the ground and tack welded to set the height.

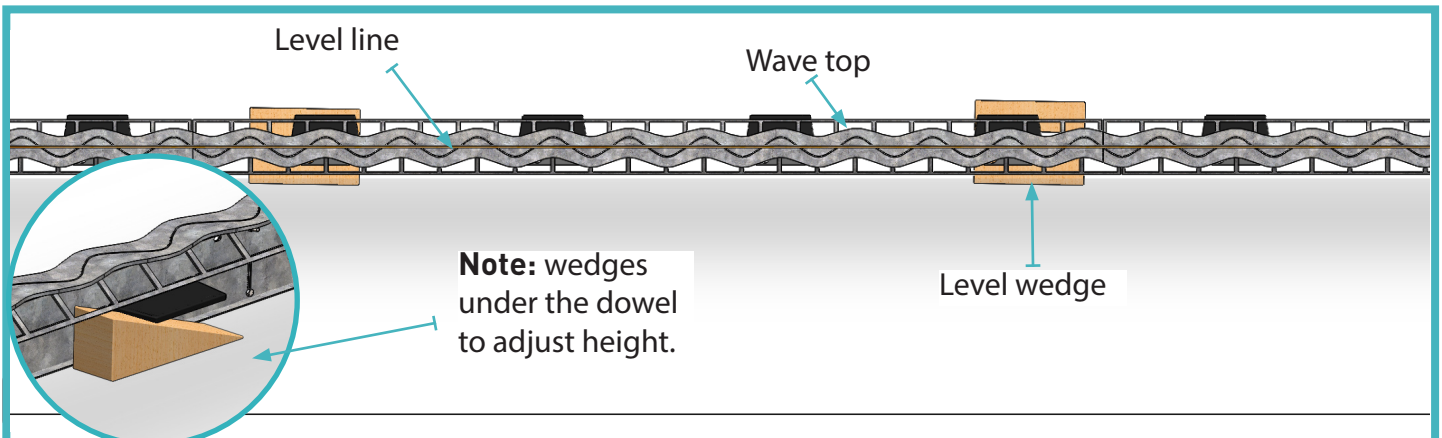

Permaban Wave Installation Guide

Using Pin and Weld Method

Installation Guide Issue V1.0
14/07/22

Measure the horizontal level using the top strip.

Note: Joints must be fixed at 90°.

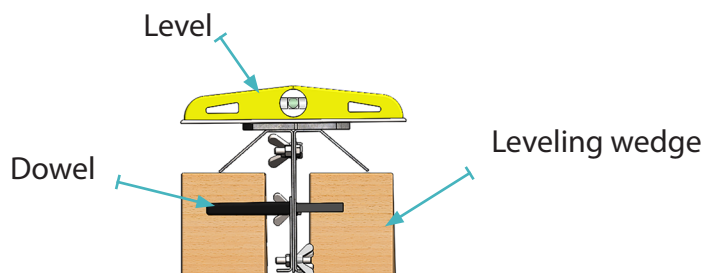

Note: Check the Joint is level in the 3 positions.

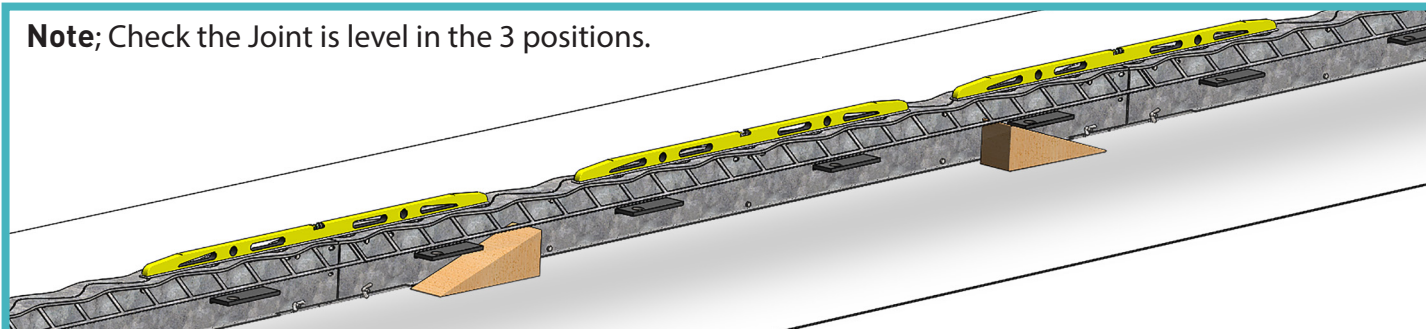

Once Joints are level hammer pins ether side of the joint and tack weld in position.

Note: 6 Pins per Joint.

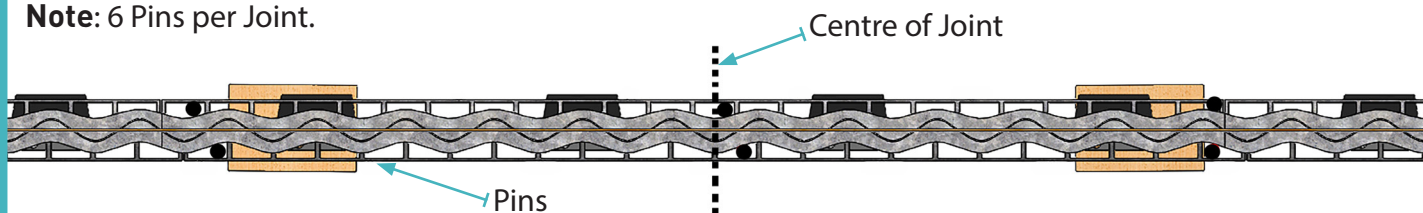

Note: Ideal placement for pin shown above.

Note: Once Pins are welded remove wedges.

04 Adjust to Height

Stand Joints end to end, and fix together using fixtures through the supplied assembly holes.

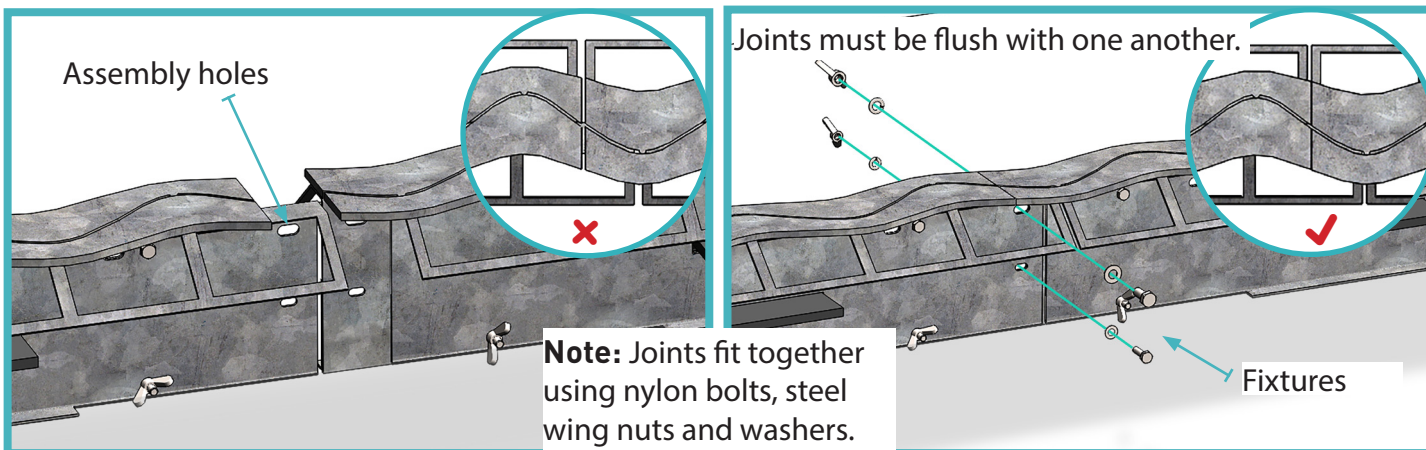

Permaban Wave Installation Guide

Using Pin and Weld Method

Installation Guide Issue V1.0
14/07/22

05 Adjust Wave extension divider plate

Loosen the wing nuts on the extension plate then tighten to set the Joint at a specific height.

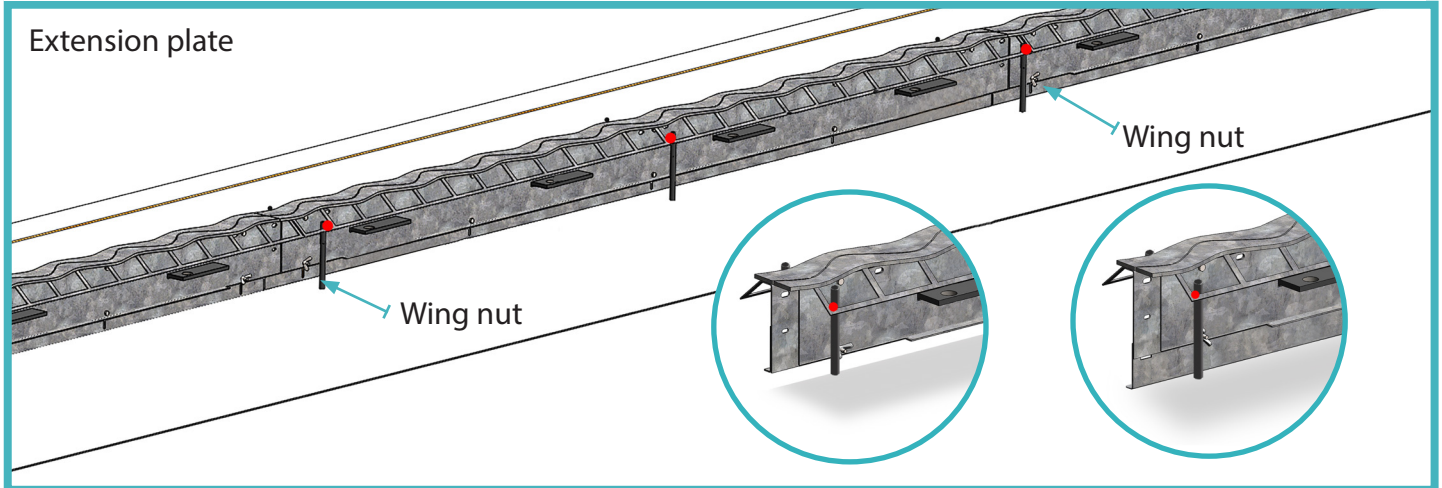

06 Support bars / Wedges

This method used 3 times along the Joint gives good support to the extension plate.

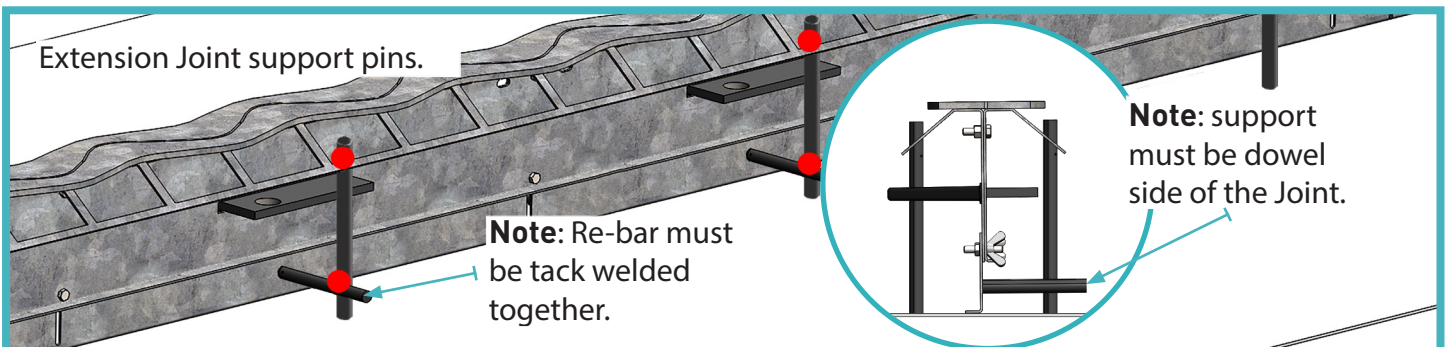

07 Vibrate Concrete

Poker vibrate along length of the Joint to compacted concrete.

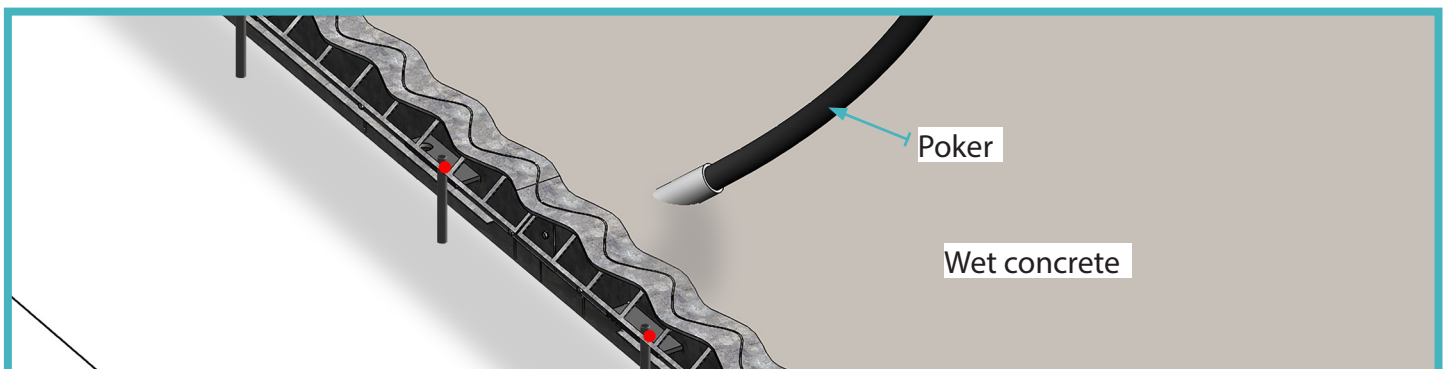

08 Finish

Finish concrete, flush to top of the Joint ensuring the rail is clearly visible.