

Permaban Wave[®] Edge

Specification Sheet
Issue 1.2
01/11/2024

Permaban Wave[®] Edge

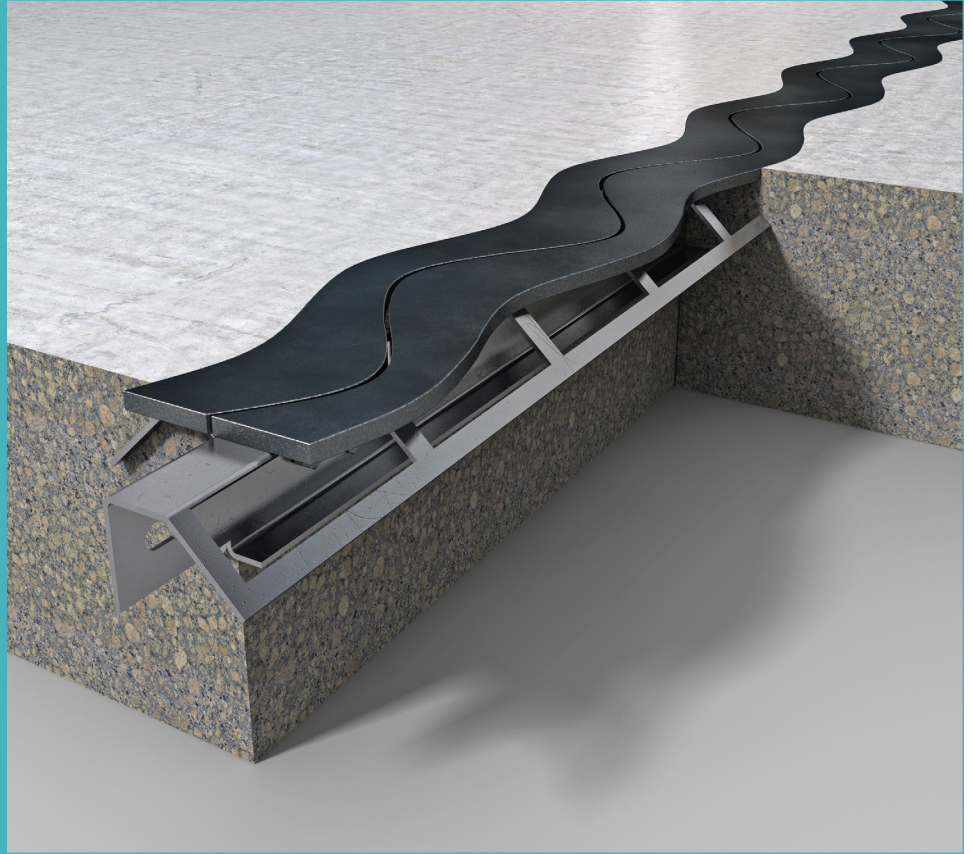

Permaban Wave[®] Edge

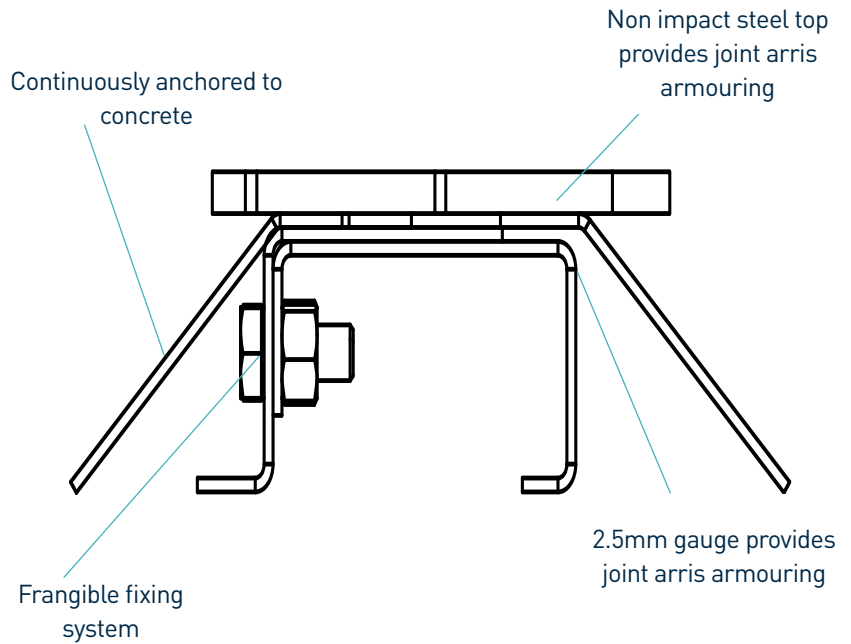

Permaban Wave® Edge

Specification Sheet Issue 1.2
01/11/2024

manufacturing tolerances

Length	±2.0mm	Height	±1mm	Straightness	±0.5mm/600mm
---------------	--------	---------------	------	---------------------	--------------

dimensions of Permaban Wave® Edge

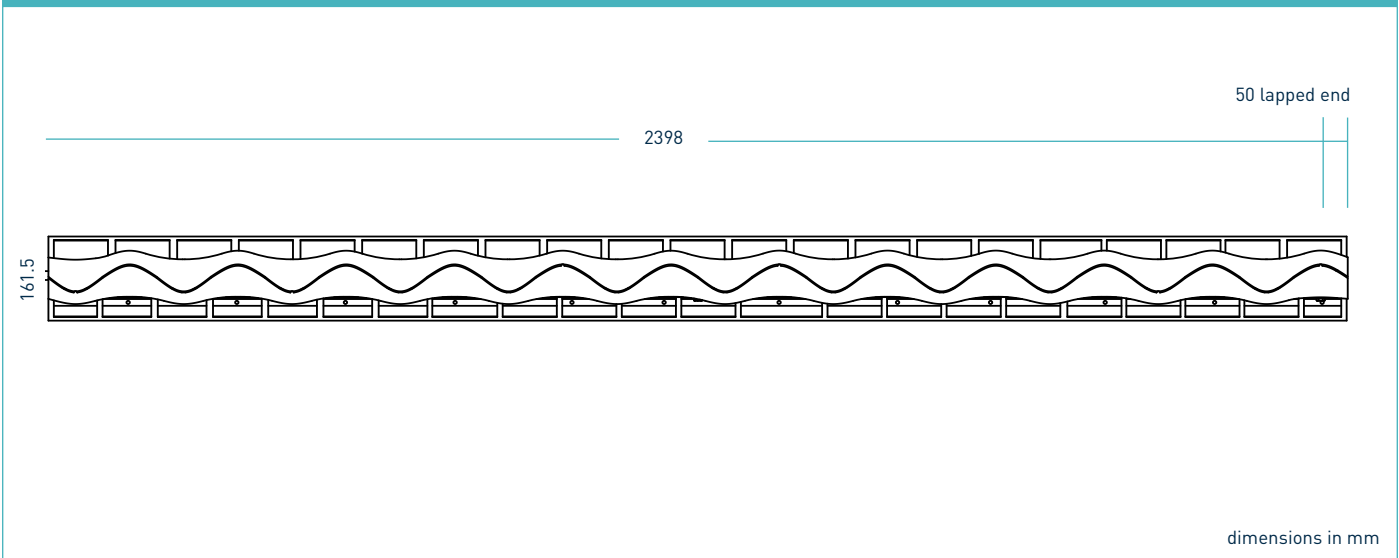

dimensions and weight of Permaban Wave® Edge

Joint Height (mm)	Length (mm)	Single Joint Weight (kg)	Number Per Bundle	Bundle Weight (kg)
161.5	2398	17	90	1655

Typical height and length values shown only. Weight values shown are approximate.

materials

Component	Material
Joint arris armouring	EN 10277-1:2018 S235JRC