

betaedge

Specification Sheet
Issue 3.6
26/03/2019

betaedge

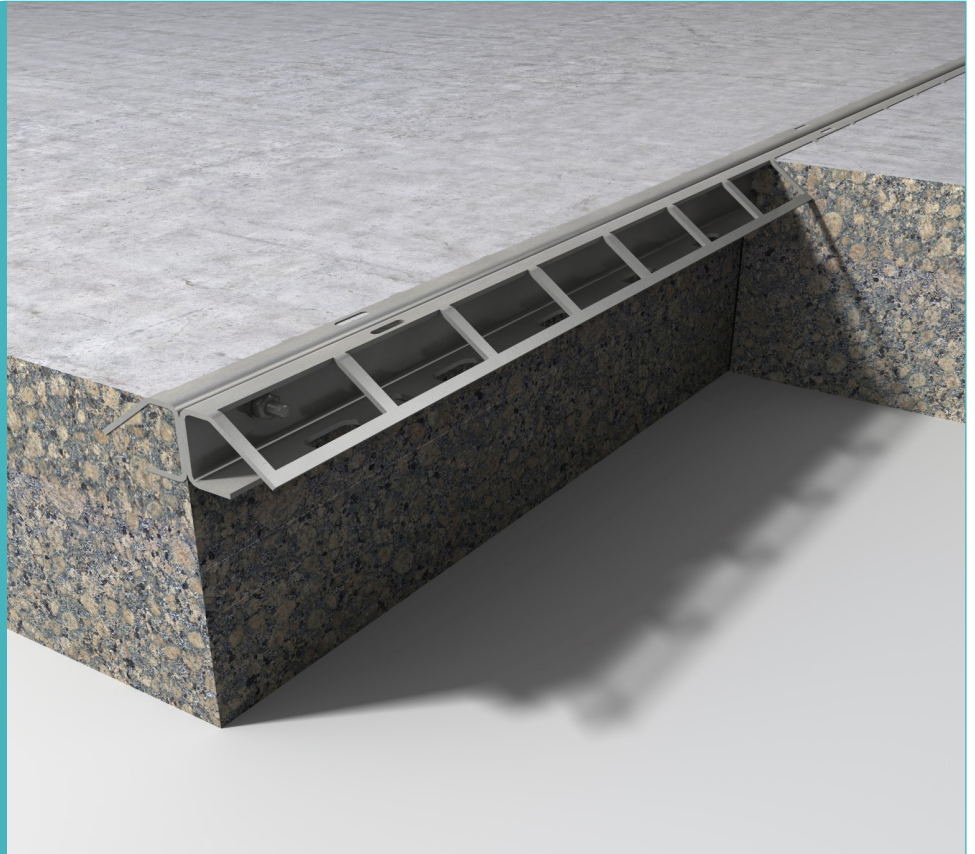

betaedge

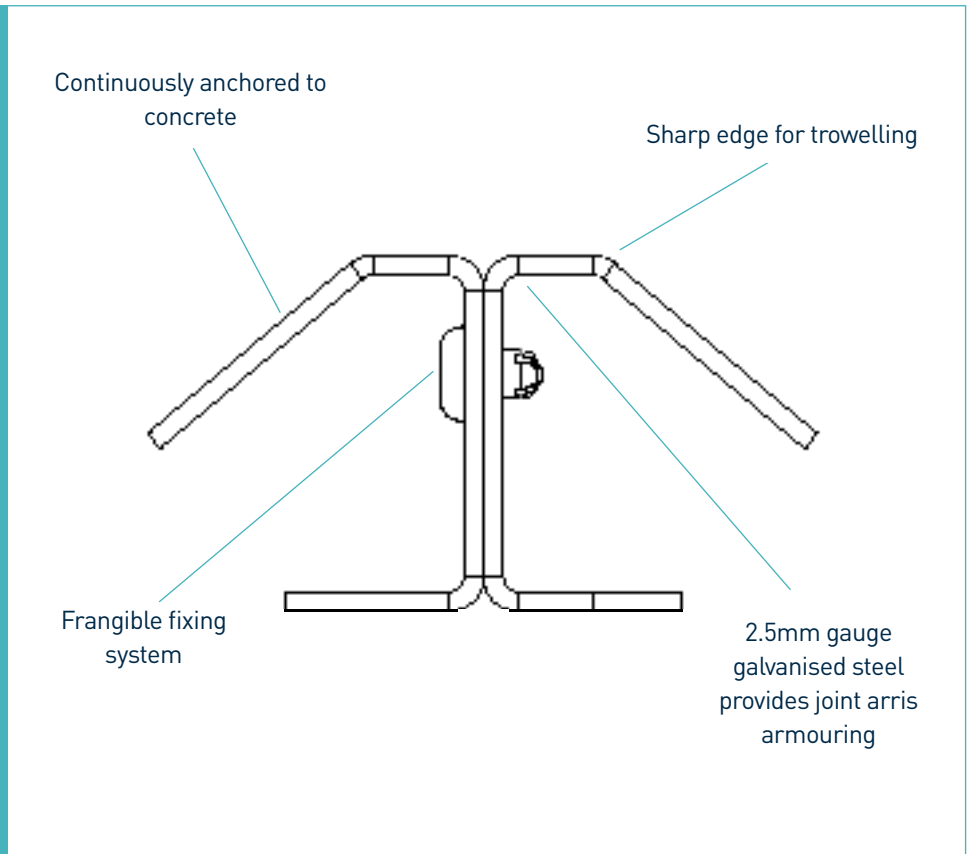

betaedge

Specification Sheet Issue 3.6
 26/03/2019

manufacturing tolerances

Length	±2.0mm	Height	±1mm	Straightness	±0.5mm/600mm
---------------	--------	---------------	------	---------------------	--------------

dimensions of betaedge

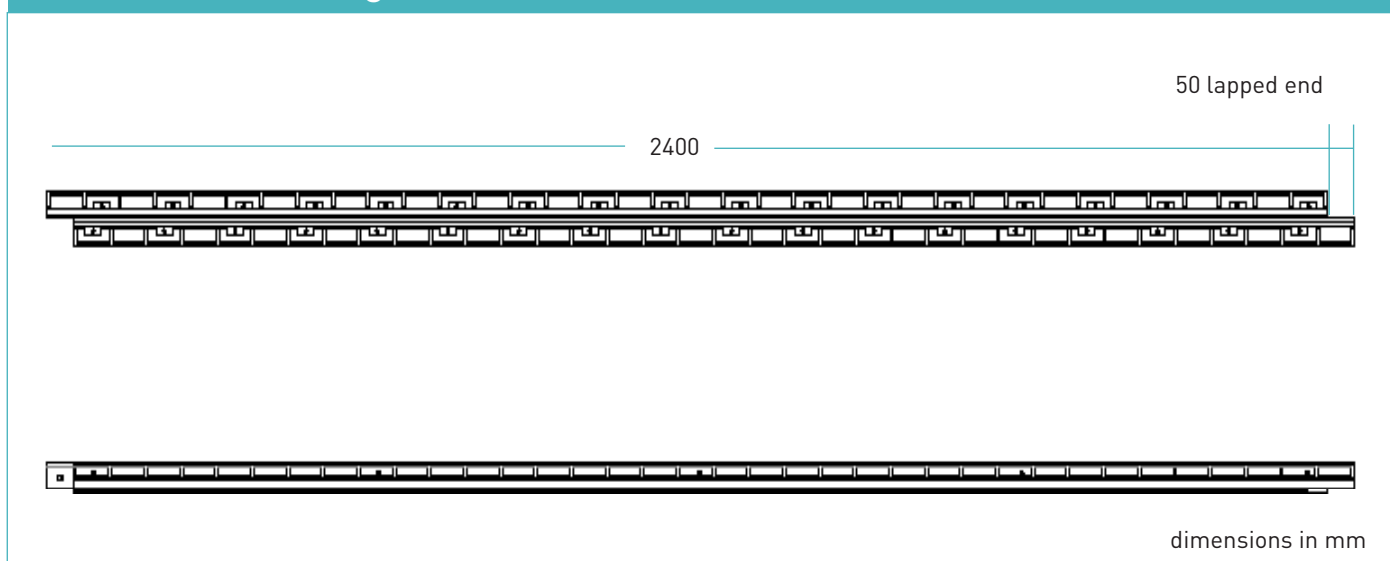

dimensions and weight of betaedge

Joint Height, h (mm)	Length (mm)	Single Joint Weight (kg)	Number Per Bundle	Bundle Weight (kg)
45	2400	5.76	240	1502.4

Typical height and length values shown only. Weight values shown are approximate.

materials

Component	Material
Joint arris armouring	EN 10346: 2015 Dx514+Z