

®

# permaban signature AR

Specification Sheet

Issue 1.1  
26/03/2019

permaban signature AR®



permaban signature AR®

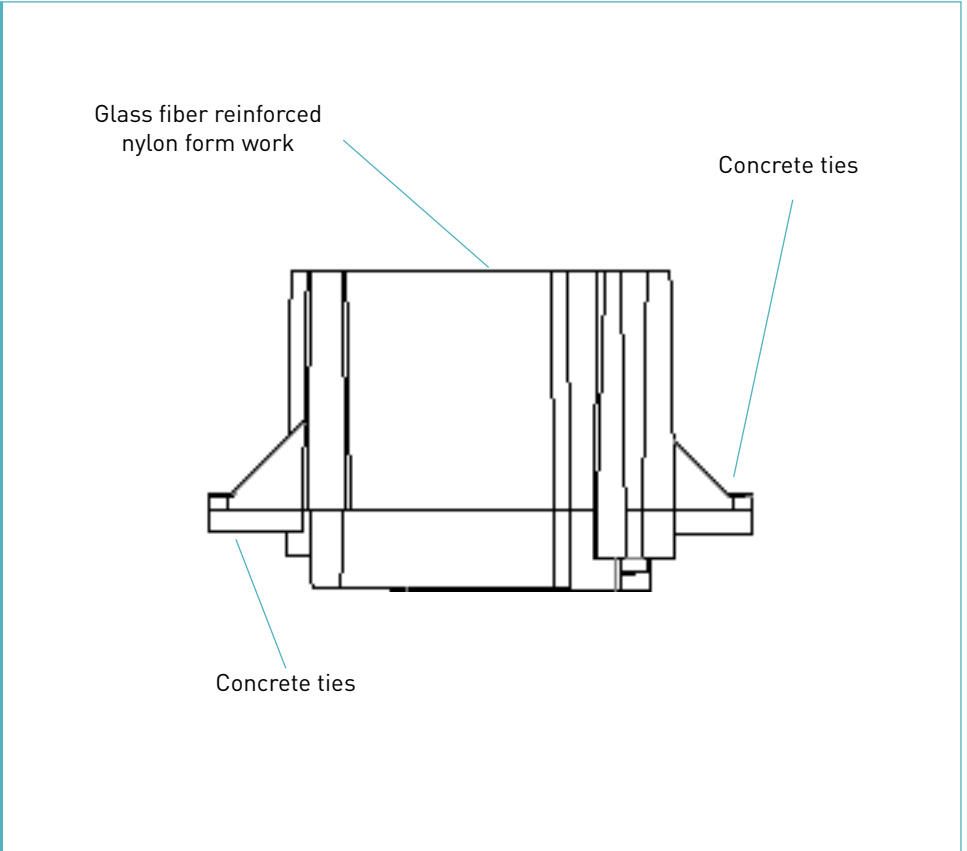

# permaban signature AR<sup>®</sup>

Specification Sheet Issue 1.1  
 26/03/2019

## manufacturing tolerances

<b>Length</b>	±2.0mm	<b>Height</b>	±1mm	<b>Straightness</b>	±0.5mm/600mm
---------------	--------	---------------	------	---------------------	--------------

## dimensions of permaban signature AR<sup>®</sup>

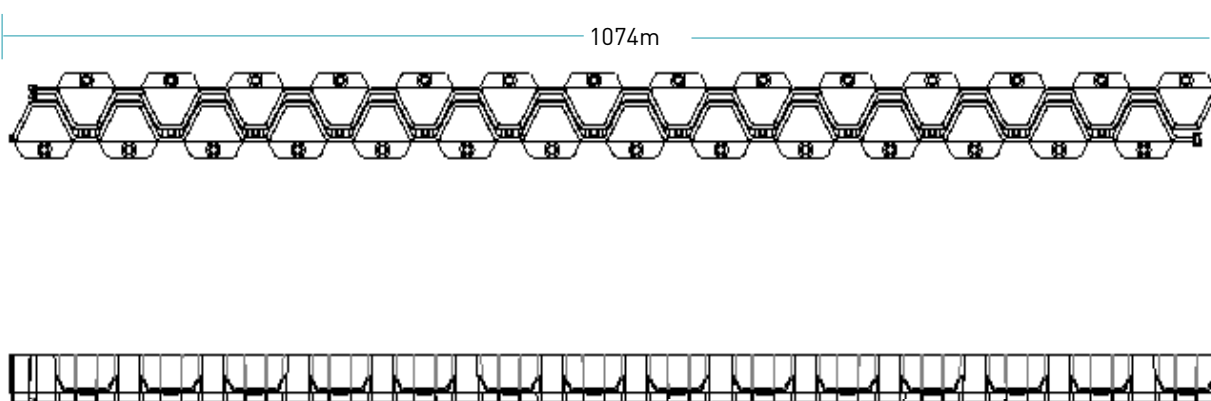

dimensions in mm

## dimensions and weight of permaban signature AR<sup>®</sup>

Joint Height, h (mm)	Length (mm)	Single Joint Weight (kg)	Number Per Bundle	Weight per bundle including packaging
40	1074	0.88	25	22 kg

## materials

Component	Material
Sheet steel formwork	Glass reinforced nylon