

Dowel Systems

Specification Sheet
Issue 3.1

01/10/2024

Dowel Systems

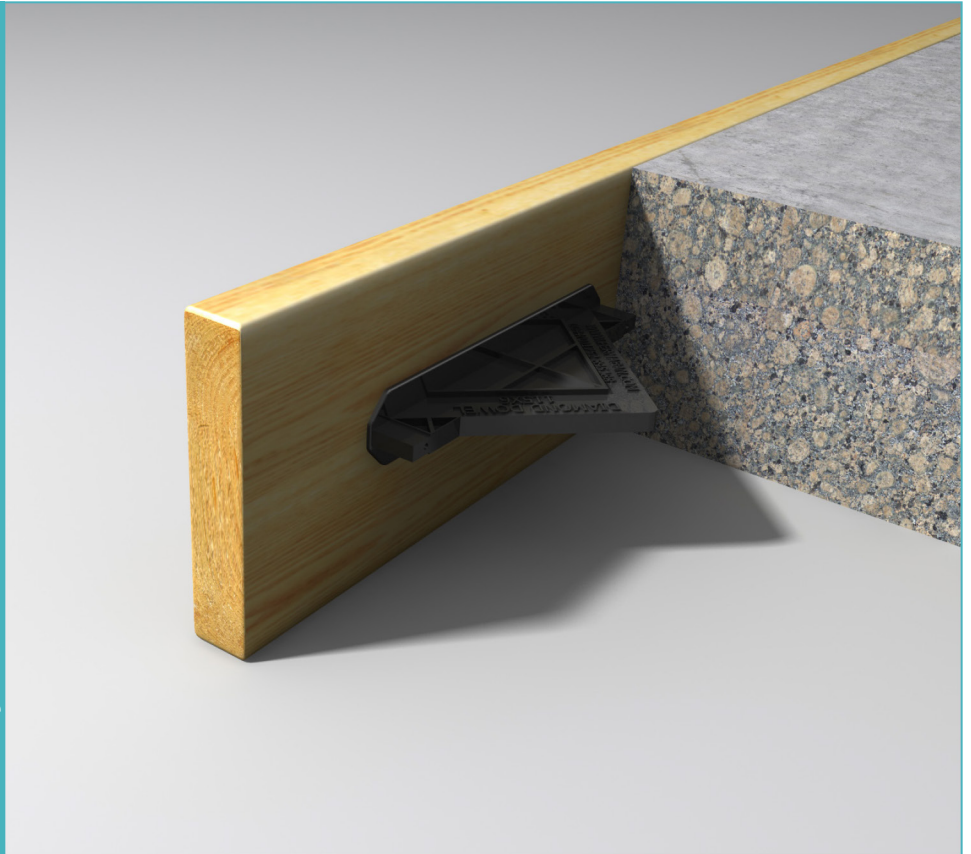

Dowel Systems

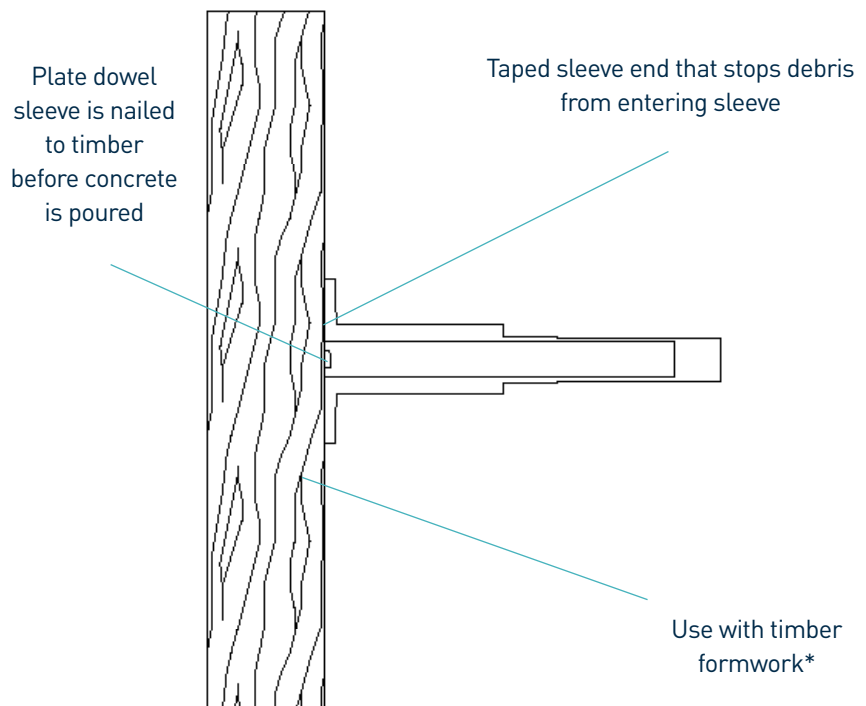

Plate dowel system shown

*Not supplied

Dowel Systems

Specification Sheet Issue 3.1
01/10/2024

manufacturing tolerances

Length ±2.0mm

Thickness ±0.4mm

dimensions of Dowel Systems

Square Dowel Bar

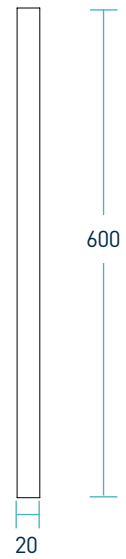
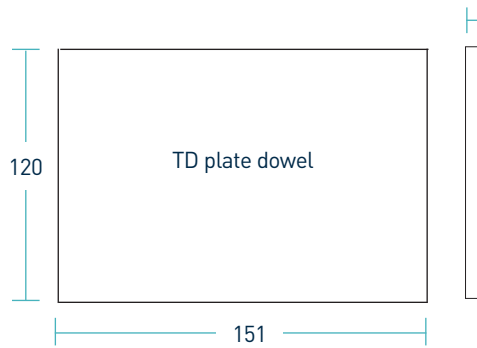
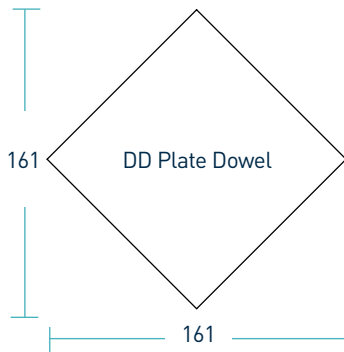

dimensions in mm

weight of packaging information

Dowel Type	Single Dowel Weight (kg)	Single Sleeve Weight (kg)
DD6 Plate Dowel	0.6	0.1
DD10 Plate Dowel	1.0	0.2
TD10 Plate Dowel	1.2	0.2
Square Dowel Bar	1.9	0.2

Weight values shown are approximate.

materials

Component	Material
Plate dowel	EN 10025-2:2004 S275JR
Plate dowel sleeve	HDPP
Square dowel bar	BS EN 10025-2:2004 S275JR
Square dowel bar sleeve	PP

Dowel Systems

Specification Sheet Issue 3.1
01/10/2024

theoretical calculated ultimate loads at failure of dowel or concrete

(For typical slabs, 40N/mm² concrete and 10mm joint opening)

		Unreinforced Slab	
Slab Depth (mm)	Dowel Type	Bending (KN/m)	Bursting (KN/m)
150	DD6 @ 450mm	38.9	103.8
	DD10 @ 450mm	38.9	212.7
	TD10 @ 450mm	31.2	168.9
	Square Bar @ 300mm	31.5	71.9
200	DD6	62.8	103.8
	DD10	62.8	212.7
	TD10	49.9	168.9
	Square Bar	42	71.9
250	DD6	61.7	103.8
	DD10	61.7	212.7
	TD10	72.6	168.9
	Square Bar	52.5	71.9
300	DD6	71.1	103.8
	DD10	71.1	212.7
	TD10	86.9	168.9
	Square Bar	63	71.9

Disclaimer: Dowels are to be inserted into the sleeve within 24 - 48 hours following the pour.

DD are spaced at 450mm, TD spaced at 600mm and Square Bars spaced at 300mm.

This table shows the load at failure in bursting (failure of the concrete) and bending (failure of the dowel) for a joint opening of 10mm - larger joint openings can be accommodated. The ultimate load has been calculated in accordance with TR34 4th Edition. Dowel position taken at mid depth of slab. For more detailed analysis please contact RCR Flooring Products Ltd.

*All design calculations should be verified by a suitably qualified structural engineer.